MT-1/NT5

User's Guide

Version 1.1 – October 2017



**IT IS ESSENTIAL THAT THIS INSTRUCTION
BOOK BE READ THOROUGHLY BEFORE
PUTTING THIS PRODUCT INTO SERVICE.**

© Copyright 2017 by Probewell Lab Inc. Printed in Canada

All rights reserved, including those to reproduce this manual or parts thereof, in any form without the express written permission of Probewell Lab Inc.

Limited Warranty

Your MT-1/NT5 comes with a two-year hardware warranty. Probewell Lab Inc., (Probewell) warrants this MT-1/NT5 against defects in material and workmanship for a period of two (2) years from the date of purchase from Probewell. This warranty applies only to the original purchaser of the MT-1/NT5 and is not transferable.

All accessories come with a two-year hardware warranty. Probewell warrants all accessories against defects in material and workmanship for a period of two (2) years from the date of purchase from Probewell. This warranty applies only to the original purchaser and is not transferable.

This warranty does not cover any damage caused neither by negligence, non-authorized modifications, or parts installed without prior written permission from Probewell.

This warranty does not apply if the product has been damaged by accident, abuse, misuse, or misapplication, nor as a result of service to the product by anyone other than Probewell.

PROBEWELL IS NOT RESPONSIBLE FOR ANY LOST PROFITS, LOST SAVINGS OR OTHER INCIDENTAL OR CONSEQUENTIAL DAMAGES ARISING OUT OF THE USE, OR INABILITY TO USE, OF THIS PRODUCT. THIS INCLUDES DAMAGE TO PROPERTY AND DAMAGES FOR PERSONAL INJURY. THIS WARRANTY IS IN LIEU OF ALL OTHER WARRANTIES INCLUDING IMPLIED WARRANTIES OF MERCHANTABILITY AND FITNESS FOR A PARTICULAR PURPOSE.

Disclaimer

Probewell Lab Inc., (Probewell) reserves the right to make changes to this document and the products which it describes without notice. Probewell shall not be liable for technical or editorial errors or omissions made herein; nor for incidental or consequential damages resulting from the furnishing, performance, or use of this material.

Features and specifications are subject to change without notice.

Table of Contents

Limited Warranty.....	2
Disclaimer.....	2
Table of Contents.....	3
List of Abbreviation.....	5
1. Introduction	7
MT-1/NT5 Overview.....	7
2. Description.....	9
MT-1/NT5 Socket.....	9
Front/Rear View of the Socket.....	10
Side View of the Socket.....	11
Handheld Remote Control.....	13
View of the Handheld Remote Control.....	14
Description of the Menus.....	17
Control Menu.....	17
Setup Menu.....	17
Load Menu.....	19
Data Logging Menu.....	20
Description of Pickups.....	22
Metercam.....	22
Optical Pickup.....	23
Functioning Theory.....	24
3. Operations	27
Operations Summary.....	28
Installation of the Socket.....	29
Operation Examples.....	32
Example 1: Solid-state 2S meter tested in Preset Mode.....	32
Example 2: Solid-state 12S meter tested in User-defined Mode.....	37
Example 3: 12S meter tested in Tracking Mode.....	39
Example 4: 4S meter tested in User-defined Mode.....	42
Temporary Configuration Menu.....	46
4. Advanced Functions	47
Record Viewer.....	47
Line Monitor Test.....	48
Creep Test.....	48
5. Configuration	51
How to Access the Configuration Menu.....	52
Description of the Sub-Menus.....	53
Kh Edition Sub-Menu.....	53
Kh Default Sub-Menu.....	54

Rev Edition Sub-Menu.....	55
Load Edition Sub-Menu	56
Preset Edition Sub-Menu.....	57
General Edition Sub-Menu	58
Factory Default Sub-Menu.....	60
Configuration Examples.....	60
6. Automatic Accuracy Test.....	63
Equipment Required	63
Procedure.....	64
User Calibration.....	69
7. Specifications	71
General	71
Handheld Remote Control	71
Test Socket Adapter	72
8. Compatible Meter Forms.....	73
Form 1S.....	74
Form 2S.....	75
Form 3S.....	76
Form 4S.....	77
Form 5S (N) Network with two CTs.....	78
Form 5S Delta with two CTs.....	79
Form 5S Delta with two CT and two VTs.....	80
Form 5S Delta with two equal-ratio CTs.....	81
Form 5S Wye with three CTs.....	82
Form 5S Wye with equal-ratio CTs.....	83
Form 5S Wye with three CTs and two VTs.....	84
Form 12S(N) Network.....	85
Form 12S Delta.....	86
Form 35S Delta.....	87
Form 45S Delta with two equal-ratio CTs	88
Form 45S Wye with equal-ratio CT and two VTs	89
9. Form Configurations.....	91
10. Troubleshooting.....	93
Error Messages.....	97
11. Parameters for Data Logging Option	101
12. Customer Service.....	103
13. Recommendations.....	105

List of Abbreviation

Abbreviation	Complete Term
A	Ampere
Amp	Ampere
AC	Alternating Current
ATK	Accuracy Testing Kit
CFM	Cubic feet per minute
CL	Class
CSV	Comma separated value
CT	Current Transformer
DSP	Digital Signal Processor
HL	High Load
Kh	Watthour constant. The number of watthours represented by one revolution of the disk. Also, called disk constant.
Kt	Test constant. For electronic (no disk) meter, the amount of energy represented by each calibrated pulse of the LED
kW	Kilowatt
Lb	Pound
LL	Light Load
NIST	National Institute of Standard and Technology
PF	Power Factor
PPI	Pore per inch
Rev	Revolution, number of revolutions
RMS	Root mean square
TA	Test Ampere

THD	Total harmonic distortion
VAC	Volt alternating current
V	Volt
VA	Volt-Ampere
VARh	VARhour (Volt Ampere Reactive hour)
Vdc	Voltage direct current
VT	Voltage Transformer
Wh	Watt-hour
W	Watt(s)
μ Wh	Micro-Watt-hour
μ VARh	Micro-VARhour

Chapter 1

Introduction

Congratulations, you have purchased the Probewell Lab MT-1/NT5, the portable single-phase meter tester available today which tests 1S, 2S, 3S, 4S, 5S (35S), 12S (both 2-phase and network) and 45S Wh meters.

MT-1/NT5 Overview

The MT-1/NT5 test socket adapter weighs only 5.7 lb, an ideal tool for field testing. Within a few minutes, a Wh meter can be accurately tested on site by meter shop technicians for periodic sampling. The MT-1/NT5 can be set to test in one step (*Mode Preset*). The MT-1/NT5 has also reverse power flow testing capability for solid state meters.

The MT-1/NT5 has a built-in 2-phase synthesized 50A current sources and a 2-phase watthour standard with an accuracy of $\pm 0.02\%$ typical, $\pm 0.05\%$ guaranteed. The MT-1/NT5 comes with a complete calibration report certifying measurement accuracy across its entire operating range on 36 points.

The handheld remote that comes with the MT-1/NT5 has a keypad and a LCD display and weighs only 0.6 lb. With the help of the simple and intuitive operation menus, the operator selects test parameters and initiates the test.

The MT-1/NT5 comes with a shock resistant carrying bag. The bag has individual compartments for the test socket adapter, the handheld remote control, the cable, the pickups and the user's guide. There is also enough space for small accessories such as the magnetic adapter for the optical pickup, seals, pliers, etc.

Chapter 2

Description

The first part of this chapter shows a detailed description of the MT-1/NT5 socket and the handheld remote control. The second part explains the functioning theory of the MT-1/NT5 tester.

MT-1/NT5 Socket

The MT-1/NT5 socket is cylinder-shaped, designed to be easily inserted in both ringless and ring-type meter bases. It weighs only 5.7 lb. A latch is available as an option for ring-type meter base.

The socket contains two 50 amps synthesized AC current sources to simulate resistive and inductive loads, a high accuracy 2-phase watt-hour standard, a true RMS multimeter and a full-duplex communication controller.

The rear of the socket has 4 standard position fixed tabs with two bypass circuits and two 90° removable twist-type tabs (twist & lock mechanism) which do not require any tools. They can be positioned at either 3, 6, 9 and 12 o'clock. The socket obtains its power directly from back tabs and accepts an input voltage from 100 to 600VAC.

The front of the socket has 8 standard fixed jaws and 2 spring loaded contact pistons. These jaws are controlled and switched automatically by the tester itself. No wiring setup is needed. The meter under test is entirely controlled by the socket.

The socket also offers a deadfront design for safer operation. The front jaws of the socket become live only when a meter is inserted.

See Appendix A for all technical specifications.

Front/Rear View of the Socket

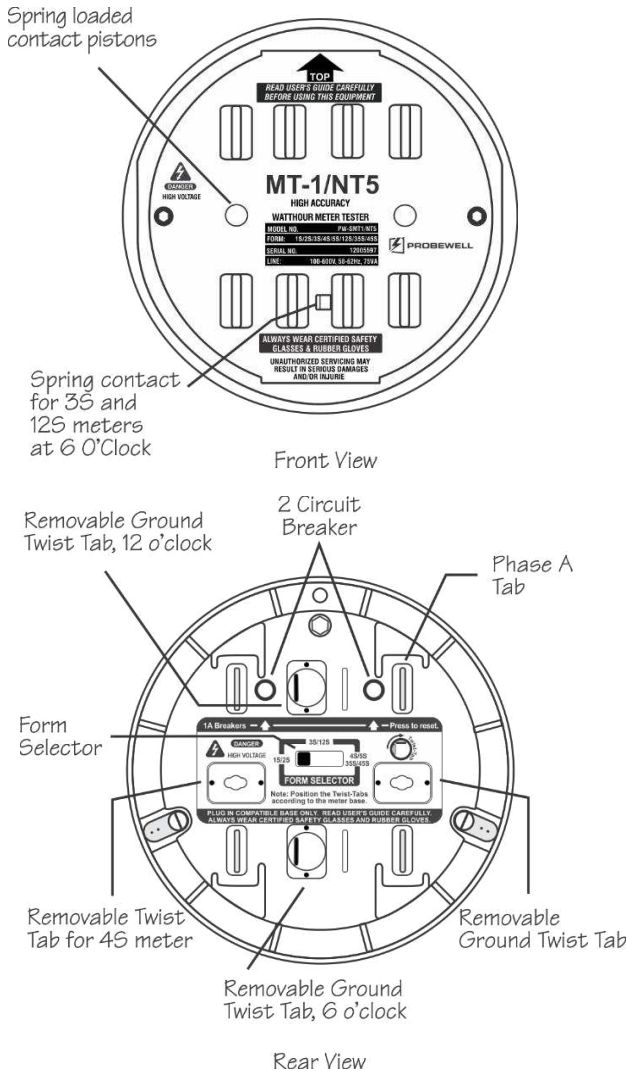

Fig. 2.1 - Front and Rear Views of the Socket

Note: Fig. 2.1 illustrates the removable twist-type tabs, which do not require any tools. These tabs can be positioned at either 3, 6, 9 or 12 o'clock.

Side View of the Socket

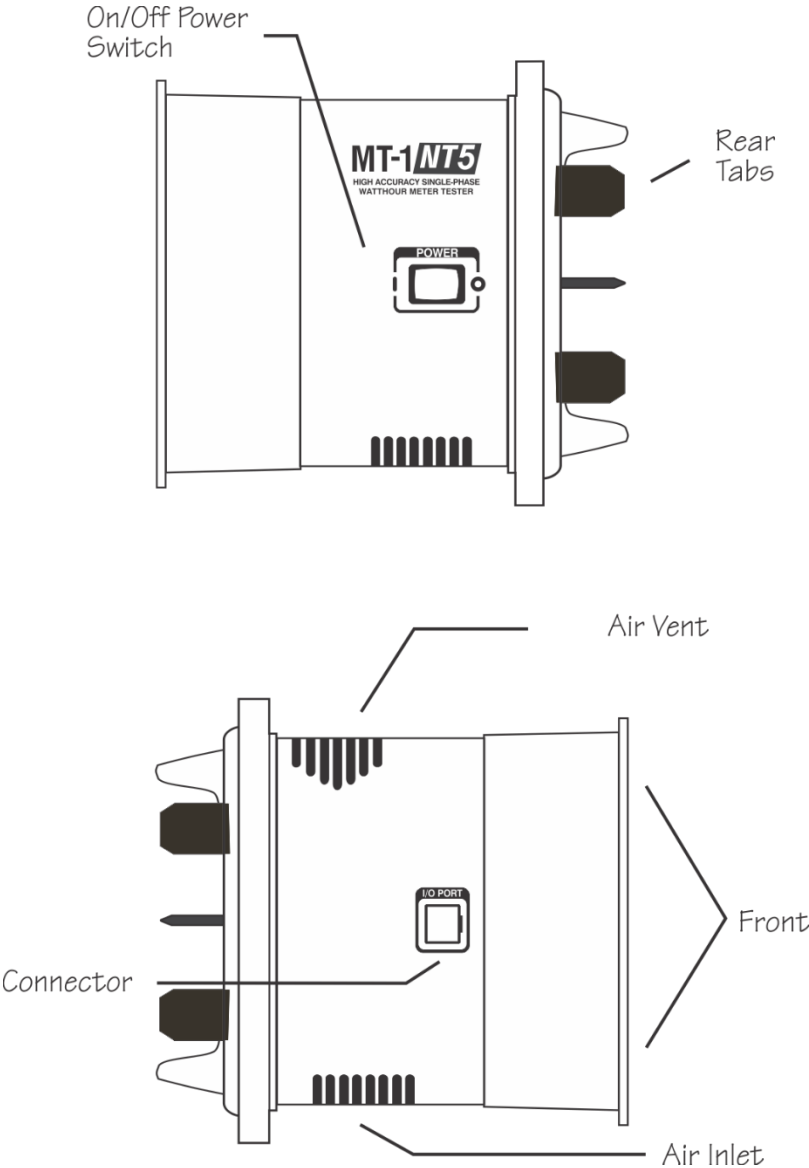

Fig. 2.2 - Side View of the Socket

Identification	Brief Description
Rear Tabs	These connect the socket to the front jaws of the meter base. The socket gets its power directly from the meter base (100VAC-600VAC) circuit. The service current shorting bars (bypasses) are rated for high capacity amperage.
Removable Tabs	These 90° hand-twist tabs can be easily inserted at 3, 6, 9 or 12 o'clock positions as required by the meter base where the test is conducted.
Power Switch	The main power on/off switch of the socket.
Front Jaws	The front jaws are controlled by internal relays allowing to test single-phase meters. The front jaws of the socket become live only when a meter is inserted. The voltage is current limited for an additional protection.
Pistons	These are actuated by the small lugs on the back of the meter when inserted for testing.
Connector	Isolated RS-232 full-duplex communication port. It also provides an isolated and current limited 12Vdc supply for the handheld remote control and accessories.
Circuit Breakers	Protection for the MT-1/NT5 and the meter. Two circuit 1A breakers which can easily be reset by pressing a spring-loaded button.
Form Selector	Slider type switch that allows to choose between Forms 1S/2S, Forms 3S/12S and Form 4S/5S(35S)/45S. In 1S/2S position, the unit is powered from the two upper tabs. In 3S/12S, it is powered from the removable ground tabs (6 or 9 o'clock) and Phase A. In 4S, it is powered from the 3 and 9 o'clock removable tabs and in form 5S(35S)/45S it is powered from the 6 and 12 o'clock removable tabs.
Air Vent ⁽¹⁾	Warm air exit. A 5 CFM miniature fan forces air circulation inside the socket.
Air Inlet ⁽¹⁾	Cool air input. Filtered through 45PPI polyurethane foam filter.

⁽¹⁾ Do not block air circulation. Keep away from direct heat or flame.

Handheld Remote Control

The handheld remote control is made of resistant ABS, weighing only 0.6 lb and holds easily in one hand. The remote control is a small device that sends commands and receive all measurements data from the socket. The remote control is connected to the socket using the extensible cable with RJ12-type quick connect plugs. There is no test voltage or current inside the remote control.

The remote control features a 4-line, 16-character LCD display and a 24-key keypad with direct access to all the test parameters and operating modes to choose from. The keys are grouped under **Control, Setup, Load and Data Logging** menus. Menus are described in the next pages.

While in test, the remote control retrieves from the socket all important measurements such as cumulative watthour energy, test voltage, test current and other test status, all of which are shown on the LCD display. After a test, the remote control displays an accuracy report in either percentage error (e.g. -0.02%) or percentage registration (e.g. 99.98%).

Data Logging operations take place once a successful test has been completed. The remote control can store up to 100 test results. The stored test results can then be viewed directly from the remote control using the built-in record viewer or uploaded to a PC using the USB device included with the optional Probewell's NTDataOne Remote Manager software.

The stored test results are CSV (comma separated value) format and can be viewed through a simple text editor file such as Microsoft® WordPad. CSV files can be easily imported to different data management software such as Microsoft® Excel, Microsoft® Access or others. See Appendix D for a description of all the fields contained in the .CSV file.

Detailed instructions are provided when this option is purchased.

View of the Handheld Remote Control

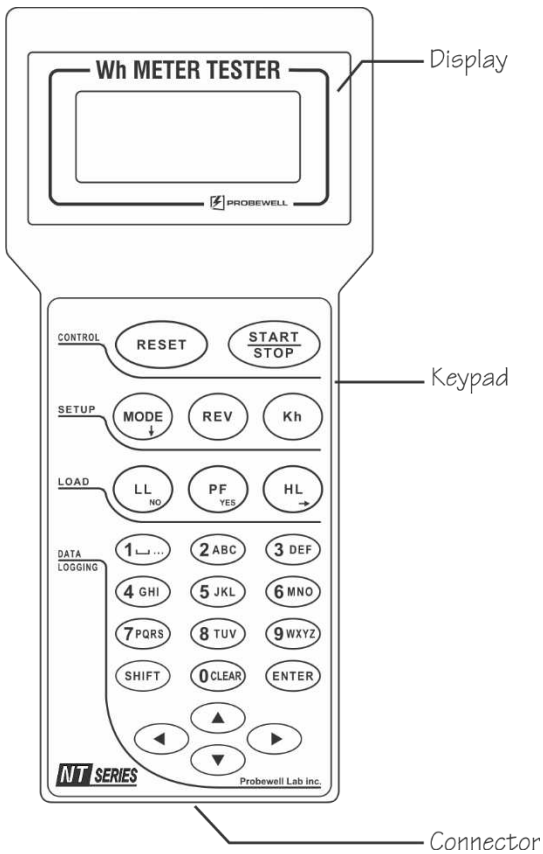

Fig. 2.3 - The Handheld Remote Control

Identification	Brief Description
DISPLAY	4-line, 16-character LCD display. Full-duplex
CONNECTOR	RS-232 communication port linking the remote control to the socket with an extensible cable (cross-wiring) with RJ12-type quick connect plugs. Note: Do not use other types of cable as they may damage the remote control and the test socket.
KEYPAD	Consists of 4 sections:
CONTROL	Has 2 keys:
Reset	Halts immediately the test in progress, if any.
Start/Stop	Ends the test in progress (if used without a pickup), if any, and starts a new test.
SETUP	Has 3 keys:
Mode	Chooses operation modes to check the meter.
Rev	Chooses the number of revolutions to be done by the meter disk under test.
Kh	Chooses the Kh corresponding to the meter under test.
LOAD	Has 3 keys:
HL	High Load current test point.
PF	0.5 Lagging Power Factor current test point.
LL	Low Load current test point.

Identification	Brief Description
-----------------------	--------------------------

DATALOGGING	Has 12 alphanumeric keys and 4 arrows for easy positioning and text edition. Data Logging takes place once a test has been completed.
--------------------	---

0 – 9: Default key settings

A – Z: Enabled with "SHIFT" key. Special characters also available.

SHIFT: Press and hold to enable the yellow printed function key.

ENTER: Confirms data entry.

ARROWS: Cursor movement:
Left/Right or Page Up/Down

SPECIAL FUNCTIONS

Backspace: Shift + Left Arrow

Insert: Shift + Right Arrow

Clear Line: Shift + 0

Edit Stack: Shift + Enter

Cursor Movement for Text Edition

When you need 2 or more consecutive letters on the same key (e.g.: C+A+B as in CABLE), press and hold the SHIFT key and press the "2" key 3 times for C. Release the SHIFT key to move over cursor and restart process for the A and B.

When you need 2 letters found on different keys (e.g.: M+E as in METER), press and hold the SHIFT key and press the "6" key once for the M then, while keeping the SHIFT key held, press the "3" twice for E. When letters are on different keys, the cursor automatically moves over when a different key is pressed.

Description of the Menus

The keys on the keypad of the remote control are grouped under four menus: **Control**, **Setup**, **Load** and **Data Logging**. These are described below and on the following pages. Please note, all default parameters in the menus can be modified according to your needs by using the Configuration Menu.

Control Menu

The **Control** menu is used for resetting the remote control and the socket and for starting and stopping a test in progress.

Reset

This key halt immediately any test in progress and reinitializes both the remote control and the socket to accept a new operator command.

Start/Stop

When a pickup is used, this key starts a test. The test in progress will end automatically when the predetermined number of disk revolutions is reached or the minimum time per test point is reached in the case of a solid-state meter.

Without a pickup, this key ends a test in progress if any, or starts a new test. The operator counts the disk revolutions manually. The starting point is critical as well the ending point for a test to be valid and accurate.

Setup Menu

The **Setup** menu is used for specifying the test mode to perform the test.

Rev

This key allows the operator to choose a predetermined number of disk revolutions per test point. By default, 7 sets of Revs are already stored in the remote control: 1, 2, 5, 10, 20, 30 and 50. Up to ten sets can be stored in the remote control.

When testing a solid-state meter with a pickup, the Rev key becomes inactive (N/A). The concept of disk revolution is replaced by a minimum time allowed per test point. By default, the minimum time per test point is at least 20 seconds.

Kh

This key allows the operator to choose the Kh corresponding to the one indicated on the meter nameplate. By default, eleven Kh are already stored in the remote control: 0.3, 0.6, 1.0, 1.2, 1.8, 3.6, 6.0, 7.2, 12.0 and 14.4, 21.6 and 36.0. Up to 18 Kh can be stored in the remote control.

When a pickup is used, a quick test is done by the socket prior to the main test to estimate the Kh of the meter. If the estimated Kh found is already stored in the remote, it is chosen to do the test. If the estimated Kh is not already stored, the user can either accept or change the estimated Kh and store it in the remote. If for some reason the Kh does not match the Kh indicated on the meter, the operator can always change it manually.

Mode

This key determines the test mode. The test mode is selected by pressing the Mode key and the up/down keys. When a pickup is used, there are two test modes available: **User-defined** and **Preset**. Without a pickup, also two test modes are available: **Manual** and **Tracking**. Modes are described hereafter:

When used with a pickup:

User-defined mode consists in choosing one out of the 3 loads to apply to the meter: HL, PF or LL. The disk revolutions or pulses are counted automatically by the pickup. No critical timing is required to start a test. The test ends automatically.

When testing a 2-phase meter [12S, 5S(35S) or 45S], you can also choose to apply the load on all phases (A+C) at the same time or on each phase individually (A or C). The phase selection is done by pressing one of the load keys one or more times. For example, by pressing two times the HL key, phase C will be selected and will be shown on the remote-control display.

Preset mode is made up of a predetermined sequence of consecutive steps and tests, all of which are done in one operation. The sequence is programmable and can be modified through the **Configuration** Menu. By default, the sequence includes one test point with each of the loads (HL, PF and LL). Please note, when testing a 2-phase meter (12S) the Preset mode offers two options: **Preset-quick** and **Preset-full**.

In **Preset-quick** mode, the MT-1/NT5 tests the 2 phases simultaneously (A+C) in one step. In **Preset-full** mode, the MT-1/NT5 does a full test consisting of the 2 phases simultaneously (A+C) followed by each phase separately (A and C).

When no pickup is used:

Manual mode is the mode where the operator counts the disk revolutions manually. The **Start/Stop** key is used to start and end the test manually. The operator can set his own parameters for conducting a test, such as the number of revolutions and the load to be applied. The load can be switched dynamically during the test.

Please note that without the help of a pickup, if you signal the start or the end of a test too soon or too late using the **Start/Stop** key, the number of disk revolutions (a whole number without fraction) might not be accurate and will affect the precision of the test.

Tracking mode is like manual mode except the remote counts and displays the number of revolutions. The count is based on the selected Kh of the meter and the cumulative watthours recorded by the MT-1/NT5 and not the physical count of the disk revolutions. The **Start/Stop** key is used to start and end the test.

Load Menu

The **Load** menu is used to determine the load current (test point): High Load(HL), Power Factor(PF), Light Load(LL).

This menu has three load keys: **HL**, **PF** and **LL**. Each sets the current load (test point) applied to the meter. By default, **HL** is set at 100% of the Test Amperage (TA), **PF** is set at 100% of the TA with 0.5 lagging power factor and **LL** is set at 10% of the TA.

Example: If the TA of the meter under test is 30A, then **HL** is set to 30A, **PF** is set to 30A (current is 60° behind applied voltage) and **LL** is set to 3A.

Data Logging Menu ⁽¹⁾

The **Data Logging** menu is used as a log for storing and viewing the test results once a test has been completed successfully.

Data Logging operations take place once a successful test has been completed with the MT-1/NT5 using a pickup.

Procedure:

Starting the Data Logging Process:

Once the test results appear on screen, the operator must do the following steps:

1. Press the **Reset** key to begin the Data Logging process.

The following display will then appear:

```
Storing data
for this test?
<LL>No  <PF>Yes
```

Afterwards the following message appears:

```
METER ID:
>
<↔> To Edit
```

2. Enter the meter ID using the keypad:

Nota. - Other questions can be programmed using the NTDataOne Remote Manager offered as an option.

3. Once completed, the saved data that will be stored in the remote's memory, up to 100 test results:

```
Ready to save?
<LL>No  <PF>Yes
```

In order to let the operator, see the test results in the field, a built-in record viewer has been incorporated in the remote control. See the chapter Advanced Functions for a description and the navigation functions.

⁽¹⁾ By default, Data Logging is enabled. To disable see the Configuration Menu.

Advanced Testing Mode

Reverse flow testing

Normally a meter measures the energy **delivered** to the customer by the grid. If the current flow is reversed the energy is **received** by the grid from the customer. Some solid-state meters have the capability to measure the energy in both directions.

It is important to mention that the reverse flow testing is available with or without the optical pickup. However, this feature is not available when a Metercam is connected.

The MT-1/NT5 has also the capability to reverse the current flow and thus test the accuracy of a solid-state meter in received flow.

First, to access the reverse flow test, make sure there is no load applied to the meter. Then you select the **Mode** you wish to use by pressing and holding the **Shift** key while pressing the **Mode** key. Please note that to show the difference between a normal and a reverse flow test, a small blinking icon (triangle) is shown on the left side of the current displayed on the remote.

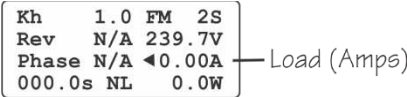

Description of Pickups

Metercam

When the Metercam pickup is used with an electromechanical meter (rotating disk), the test becomes fully automatic by pressing only one key.

The Metercam is a digital disk sensor without the many drawbacks found on usual photoelectric sensors, such as difficulty to align properly and sensitivity to light. With the Metercam, no alignment is necessary since it detects and picks up the disk by itself. Another feature is its electronic shutter which makes it insensitive to light variations including bright sunlight.

The Metercam is built around a miniature digital camera with a 1/2" field view combined with a RISC processor that detects the position of the meter disk and locks automatically on the reference point (black flag).

The Metercam is mounted on four suction cups installed directly on its backside. These sticks quite well on most meter covers. Thus, the Metercam can be installed within a few seconds.

For a good and lengthy hold, lightly wet the inside of the suction cups, especially when field testing in colder weather. Also, keep the inside of the suction cups clean.

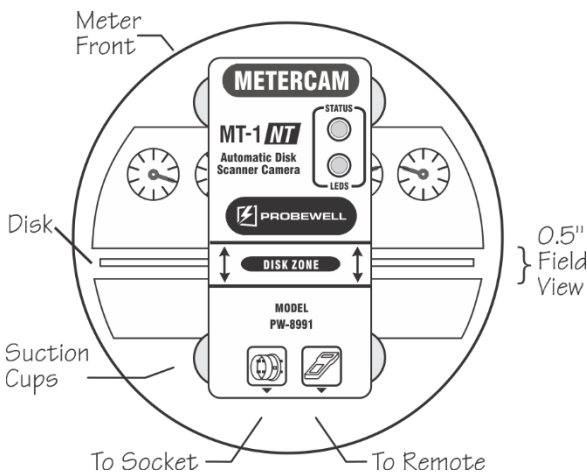

Fig. 2.4 - Metercam

Optical Pickup

When the optical pickup is used with a solid-state meter the test becomes fully automatic by pressing only one key.

The optical pickup is mounted with a suction cup that detects infrared light pulses from solid-state meters. The optical pickup uses edge triggering for less sensitivity to changes. On the top of the suction cup, there is a pulse indicator in the form of a visible red led that flashes when pulses are being received.

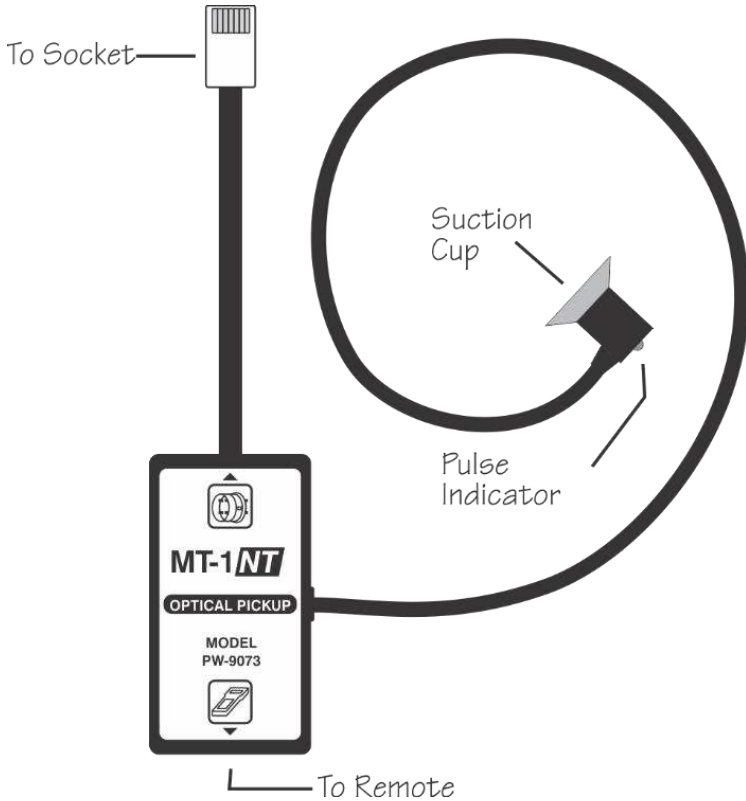

Fig. 2.5 - Optical Pickup

Note: A magnetic optical pickup adapter is available when testing meters equipped with a metallic port. Another adapter is also available for Landis & Gyr Focus meters.

Functioning Theory

MT-1/NT5 applies a load to the meter under test then measures exactly the quantity of energy that passes through the meter. After a predetermined number of disk revolutions or time period, the test ends and the remote control displays the difference in percentage obtained by the meter and the MT-1/NT5 internal watt-hour standard. This difference can be read as a **percentage error** or as a **percentage registration**. The **Configuration** Menu allows the choice of one or the other.

Percentage error is the difference between the recording in percentage and 100%. *Example:* a meter having a percentage error of -5% is considered slow by 5%; it measures less energy. The result should be nearest 0% for an accurate meter.

Percentage registration is the relation between the recording obtained by the meter and the true value measured during a specific period, expressed in percentage. *Example:* a meter having a percentage registration of 105% is considered fast by 5%. It should be nearest 100% for an accurate meter.

Current Applied to the Meter

The current applied to the meter under test is achieved by two independent built-in 50A synthesized AC current sources. The current level is adjustable and regulated. The current sources allow to simulate loads at unity and 0.5 lagging power factor. They are isolated and form two independent current loads in closed-link arrangement. This configuration allows to check a meter without the need to open the potential link of the meter and no wiring setup is necessary.

Voltage Applied to the Meter

The voltage applied to the front jaws is derived from the meter base circuit. For safety reasons, the voltage is applied to the front jaws only when a meter is inserted. The voltage is also current limited.

The front jaws of the MT-1/NT5 are controlled by internal relays allowing to test 2-phase and single-phase watt-hour meter Form configurations without wiring setup.

Internal Watthour Standard

The internal watthour standard in the MT-1/NT5 has an exceptional accuracy due to the use of electronic transducers developed by Probewell. The transducers have an exceptional long-term stability and linearity and are not affected by temperature.

The internal watthour standard does not contain any potentiometers or other types of screw adjustment that could become unstable with time but uses digital technology to ensure a maximum of reliability over years. A Digital Signal Processor (DSP) measures and calculates the exact energy that passes through the meter. This has the advantage of obtaining a more compact and lightweight watthour standard.

The MT-1/NT5 internal watthour standard is calibrated using a primary standard traceable to the National Institute of Standards and Technology (NIST) and comes with a complete calibration report certifying measurement accuracy over its entire operating range on 36 points. Test accuracy can be done in your own lab using a primary or secondary standard with the Single-Phase Accuracy Testing Kit (ATK-4).

The calibration of the MT-1/NT5 watthour standard can be changed by steps of $\pm 0.001\%$ using the **User Calibration** menu. However, the User Calibration is limited to a maximum of $\pm 0.05\%$. User Calibration is stored in the non-volatile memory of the socket. The socket contains a unique internal serial number that identifies its internal watthour standard.

Chapter 3

Operations



CAUTION!

The use of MT-1/NT5 is strictly reserved to personnel authorized to manipulate electric installation meters. For safety reasons, ***certified safety glasses and rubber gloves*** are strongly recommended but are not provided with the MT-1/NT5.

The operation of removing and inserting a meter from its meter base under power exposes live electric terminals. **Be careful. Do not stick your hands or any metal objects into the open meter base. You could suffer bodily burns, electric shocks and even electrocution.**

It is imperative you **follow the safety procedures** of your company.



WARNING!

Do not install the MT-1/NT5 into a 3-phase meter base.

Operations Summary

The MT-1/NT5 is compatible with meter Forms 1S, 2S, 3S, 4S, 5S(35S), 12S and 45S. Before testing a meter in the field, always make sure the electrical wiring of the meter base is fully compatible with those shown in Appendix B.

The MT-1/NT5 socket must first be inserted between the meter base and the meter. The installation procedure for a ringless meter base is described in fig. 3.1.

After powering on, the MT-1/NT5 recognizes the type of meter installed and asks to validate the Form and the TA. With some meters, it is sometimes necessary to select the Form manually.

The AutoKh is another feature that can be enabled or disabled. When enabled, if a pickup is used, a quick test is done by the socket to estimate the Kh of the meter. If the estimated Kh found is already stored in the remote, it is chosen to do the test. If the estimated Kh is not already stored, the user can accept or change the estimated Kh and store it in the remote. Without a pickup, the Kh is chosen according to the meter Form as defined by default in the remote. If for some reason the Kh does not match the Kh indicated on the meter, the operator can change it manually. When the AutoKh is disabled, the system only verifies that the pickup is working. Then, the user selects the Kh as if there are no pickups.

Then a test mode is chosen to do the test. If a pickup is used, the test becomes fully automatic and the modes User-defined and Preset are available. Without a pickup, the modes Manual and Tracking are available and the test is done manually and the meter disk (or the simulated disk in case of a solid-state meter) must do a precise whole number of revolutions and it is up to the operator to start and stop the test precisely using the key Start/Stop.

Once the load is applied and the test has started, the MT-1/NT5 measures with its internal watthour standard the energy that passes through the meter. All important measurements are shown on the remote display while testing.

When the test ends, the remote control displays the test result, i.e., energy measured by the MT-1/NT5 internal watthour standard, the energy measured by the meter followed by a percentage error (e.g. -0.02%) or a percentage registration (e.g. 99.98%) report.

Installation of the Socket

1. Meter Removal

Carefully remove the meter from its meter base according to your company's safety procedure.



WARNING!

Do not remove the meter when it is under a heavy load to avoid sparks. The front jaws of the meter base are live; do not stick your hands or any metal objects into the meter base! Certified safety glasses and rubber gloves are strongly recommended.

Make sure that the wiring connecting the meter to the line is compatible with one of the configurations shown in Appendix B.

If a meter base is not compatible with the MT-1/NT5, stop here and put the meter back into place. Field-testing with the MT-1/NT5 is not possible for that particular meter installation.

2. Installation of the MT-1/NT5 Socket*

Make sure the power switch of the MT-1/NT5 socket is off. Before plugging in the socket adapter, slide the Form Selector in the position according to the Form of the meter being tested. For 12S meter bases, check that the twist tab is inserted correctly either at 6 or 9 o'clock. For the 5S, 35S and 45S insert correctly the removable tabs at 6 and 12 o'clock position (see Appendix C for positioning)

Firmly take the MT-1/NT5 socket with the arrow pointing upward and align the rear tabs of the socket with the front jaws of the meter base. Then firmly insert the MT-1/NT5 socket into the meter base. Secure the installation. Please note that a latch can be purchased as an option for ring-type meter bases.

3. Installation of the Meter

Plug in the meter into the front of the MT-1/NT5 socket. Make sure everything is secured. The socket installation is complete.

Operation examples are provided further on.

* When the MT-1/NT5 is used in the shop, do not plug it in a test board. It will not run properly. You may use a regular meter base of at least 150VA capacity. You must keep the Form Selector in the 1S/2S position for all types of meters. The nominal voltage must be respected according to the meter being tested.

Installation Procedure (ringless meter base)

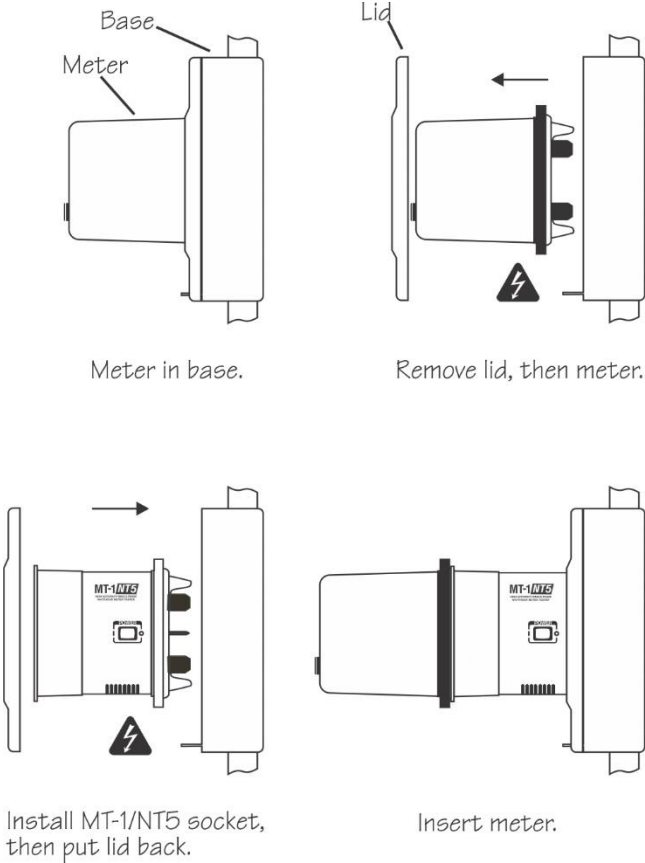



Fig. 3.1 - Installation into a Ringless Meter Base.

 **THIS SYMBOL INDICATES THAT VOLTAGE IS PRESENT AND EXTREME CARE SHOULD BE USED.**

INSTALL THE MT-1/NT5 SOCKET ONLY IN A COMPATIBLE METER BASE. SEE APPENDIX B FOR COMPATIBILITY.

Operation Examples

In the following examples, we assume the MT-1/NT5 socket is already installed into the meter base and the meter under test is also plugged into the MT-1/NT5 socket and the installation is well secured.

Example 1: Solid-state 2S meter tested in Preset Mode

Meter used: Solid-State, Form 2S
Voltage: 240
Kh: 1
TA: 30
CL: 200

The **Preset** mode is chosen which consists to apply loads of at least 20 seconds for HL, PF or LL.

Here are the steps to be followed:

1. Connecting the cables
2. Switching ON the tester
3. Pulse detection and Kh estimation
4. Initialization
5. Loading and Testing
6. Checking Results while testing
7. Obtaining the test results

1. Connect the cables

To connect the cables:

1. Plug the RJ12 connector of the straight cable of the optical pickup into the test socket telephone connector.
2. Connect the handheld remote to the optical pickup using the coiled cable. Be careful not the reverse the cables otherwise it will not work
3. Look for the LED output pulse of the meter and put the suction cup of the optical pickup directly over it.

Note: An optional adapter may be required on some meters and can be purchased as an option

2. Switching ON the Tester

Switch on the MT-1/NT5. The remote self-tests and a display appears which indicates the Form and the TA of the meter, 30A being the TA by default.

```
METER TYPE
FM: 2S   TA: 30
<ENTER>  <←→>
```

If the Form and the TA displayed are correct as shown above press **Enter**, otherwise use the arrow keys to change them.

3. Pulse Detection & Kh estimation

Once the remote control has detected the presence of the optical pickup the following display appears.

```
OPTICAL PICKUP
V1.5 INSTALLED
Waiting ..?
```

Then a quick test is done automatically to estimate the Kh of the meter. If the estimated Kh found is already stored in the remote control, it is chosen to do the test. Otherwise, you can accept or change the estimated Kh and store it in the remote. If for some reason the Kh does not match the meter, you can always change the Kh manually. The following display appears for a few seconds:

```
OPTICAL PICKUP
V1.5 INSTALLED
Pulse found
```

4. Initialization

Once the pulses have been found, the following display appears:

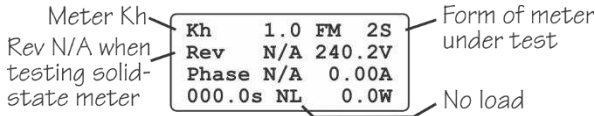

To make sure that the mode is **Preset**, press the **Mode** key and the following display will appear:

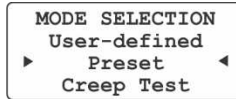

Press **Mode** again to come back to the test menu.

5. Loading and Testing

Press **Start/Stop** to initiate the sequence; the load current will increase to HL and the meter will start to send pulses and the internal watt-hour standard begins to register the energy that passes through the meter. At the same time, you will hear a double beep indicating that the test has begun.

In addition to the test parameters appearing on the display, the operator can see the voltage and current applied to the meter, the chronometer and the cumulated energy registered by the watt-hour standard. A typical running test display is shown below.

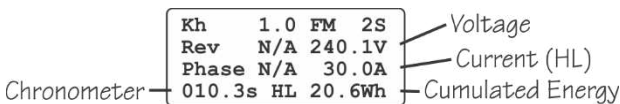

6. Checking the results while testing

While testing, you can check the partial results of the test by pressing the **Mode** key.

TEST	REPORT
HL:	100.04%
PF:	Testing
LL:	-

Press **Mode** again to come back to the test menu.

7. Test Results

After the 3 test points, the watt-hour measurement period ends automatically. Then the load is removed and three test results are displayed, one for HL, one for PF and one for LL. A typical test result is shown below with the 3 test points:

TEST	REPORT	
HL:	100.04%	Accuracy at HL
PF:	100.00%	Accuracy at PF
LL:	100.02%	Accuracy at LL

A fourth test results is available, showing the average according to the ratio chosen. By default, it is 4:1 according to the formula $(4HL+1LL)/5$. You can see the weighted result by scrolling down one line with the help of the arrow/down on the keypad. Here is a typical display showing the 4 test results together:

HL:	100.04%	Ratio (4:1) using $(4*HL+LL)/5$ formula
PF:	100.00%	
LL:	100.02%	
Weight:	100.03%	

Note that when you see the cursor symbols on the upper right end of the display, this mean that you can scroll down line by line. You can also press the left/right arrows to view page by page.

At this time, you can save your test results by pressing the **Reset** key as shown below:

Storing data for this test?	
<LL>No	<PF>Yes

Press **PF** to start the saving procedure. If you do not want to save these results, then press **LL**. Data Logging operations are detailed on page 20.

Ready to save?
<LL>No <PF>Yes

Example 2: Solid-state 12S meter tested in User-defined Mode

Meter used: Solid-State, Form 12S
 Voltage: 120
 Kh: 1
 TA: 30
 CL: 200

The **User-defined** Mode is chosen which consists in applying a HL load during at least 20 seconds. Once the installation completed and steps 1 to 3 described in example 1, we proceed with the initialization.

1. Initialization

Press the **Mode** key and choose **User-defined**.

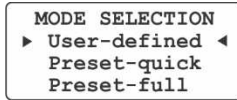

Press **Mode** again to come back to the test menu.

2. Loading and Testing

Press **HL**, the load current will increase to 30A and the meter will start to send pulses. In the following display, the meter sees a load of 6.97kW (voltage x current x 2):

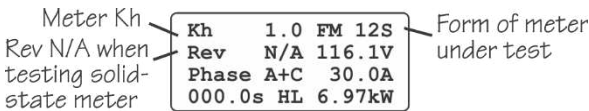

Note: At this time, if you wish to test only Phase A, press **HL** a second time. If you wish to test only phase C, press **HL** another time and so on. Below is a display where only phase C is selected. The selection is shown on the third line in the middle of the screen.

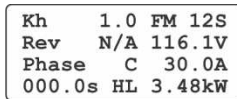

By pressing one time on **HL**, phases A+C are again selected, as per this example.

Press **Start/Stop** to start the test. The meter sends pulses and the internal watt-hour standard of the MT-1/NT5 starts measuring the energy sent to the meter. At the same time, you will hear a double beep indicating that the test has begun.

In addition to the test parameters appearing on the display, the operator can see the voltage and current applied to the meter, the chronometer and the cumulated energy registered by the watt-hour standard. A typical running test display is shown below:

Phase under test	Kh	1.0 FM 12S	Voltage	
	Rev	N/A 116.3V		
	Phase	A+C 30.0A		Current (HL)
	016.9s HL	32.7Wh		
Chronometer		Cumulated Energy		

On this display, the internal watt-hour standard of the MT-1/NT5 shows that it has registered up to now 32.7Wh (voltage x load x time x 2). When calculating Wh, time is expressed in hours.

3. Test Results

The watt-hour measurement period ends automatically after the minimum time of test by default, here >20 seconds. Then the load is removed automatically and test results are displayed. A typical test result is shown below.

Energy measured by the MT-1/NT4	PHASE	A+C	Energy measured by the meter (Kh x #pulses)	
	Mt-1	39.9960Wh		
	Meter	40.0000Wh		Accuracy at HL
	HL:	100.01%		

The test result shows this meter has a percentage registration of 100.01% under a 30A load. By default, the test result is displayed in percentage registration. Then, by pressing the **Reset** key, you can store the results of your test or not.

Please note that you can abort a test at any time by pressing the **Reset** key.

Example 3: 12S meter tested in Tracking Mode

Meter used: Solid-State, Form 12S
Voltage: 120V, 3-wire network
Kh: 14.4
TA: 30
CL: 200

Tracking Mode is chosen which consists in applying a 30 A (HL) load over 10 revolutions. **No pickup** is used for this test. The **Start/Stop** key is used to start and end the test.

We assume that the installation procedures have been completed. Connect the coiled cable from the remote control to the test socket. Switch on the MT-1/NT5. After a few seconds, the remote control displays the form and the TA of 30A. Here the form detected by the MT-1/NT5 is 12S because the meter has a 9 o'clock contact terminal that presses down on the proper piston on the front of the test socket. However, if a meter has a 6 o'clock terminal, the form detected would be 2S. In that case, use the **up/down** arrows on the keypad to select form 12S instead of 2S. Once the proper form appears, press **Enter**.

1. Initialization

Press the **Mode** key and choose **Tracking**.

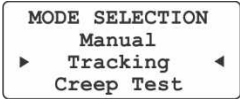

Press **Mode** again to come back to the test menu.

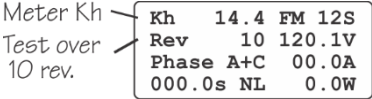

By default, the selected Kh for a 12S meter is 14.4. It can be changed by using the Kh key. The test is done over 10 revolutions by default. It can be changed by using the Rev key.

2. Loading and Testing

Press **LL** the load current will increase to 3A and the disk will start to rotate. When the black flag of the disk lines up with the black line (on the meter nameplate), press **Start/Stop** to initiate the test. At this precise moment, the internal watt-hour standard of the MT-1/NT5 begins to register the energy that goes through the meter. Note: it is easier to start and end a test when the disk rotates slowly.

On this display, the internal watt-hour standard measures the energy that passes through the meter:

Kh	14.4	FM	12S
Rev	0/10	120.1V	
Phase	A+C	3.00A	
001.2s	LL	0.24Wh	Wh

Press on **HL**. The current will increase to 30A and the disk will rotate rapidly. See display below:

Completed Revolutions	Kh	14.4	FM	12S
	Rev	4/10	120.1V	
	Phase	A+C	30.0A	Current
	029.9s	HL	57.6Wh	

The remote control emits a beep each time the disk has completed one revolution. The number of completed revolutions also appears on the display. The count of the revolutions is based on the meter Kh and the Wh recorded by the MT-1/NT5.

At the 9th revolution, the sound of the beep is different to warn that the end of the test is near. At this time, press **LL** to slow down the disk then, when the black flag of the disk lines up with the black line, press **Start/Stop** to end the test.

3. Results

The results are shown on the display.

	PHASE	A+C	
Energy measured by the MT-1/NT4	Mt-1	144.100Wh	Energy measured by the meter (Kh x rev) Accuracy at HL
	Meter	144.000Wh	
	LL:	99.93%	

The result indicates that the meter is accurate at 99.93% under a load of 30A, therefore slightly slow by -0.07%. Remark: On the fourth line of the display, it is normal to see LL instead of HL because the last revolution was ended in LL. However most of the test was conducted at HL, even if LL is displayed in the result.

Note: The results of a test in **Manual** or **Tracking** modes cannot be saved.

Example 4: 4S meter tested in User-defined Mode

Meter used: Solid-State, Form 4S
Voltage: 240V
Kh: 0.6
TA: 2.5
CL: 10

User-defined Mode is chosen which consists in applying a 2.5A load during 10 revolutions. The **Metercam** is used for this test. We assume that the installation procedures for the socket have been completed.

Here are the steps to be followed:

1. Installing the Metercam and the cables
2. Switching ON the MT-1/NT5
3. Disk detection
4. Initialization
5. Loading and Testing
6. Obtaining results

1. Install the Metercam and the cables

Install the Metercam and the cables:

1. Roughly align the 0.5" field view disk zone of the Metercam with the meter disk.
2. Press the four corners of the Metercam onto the meter cover hard enough to allow the suction cups to take hold.
Notes: Make sure that the 4 suction cups stick perfectly on the meter cover **during the entire test**. If necessary lightly wet the inside of the suction cups.
3. Connect the coiled cable from the socket to the bottom left connector of the Metercam.
4. Connect the other coiled cable from the remote to the bottom right connector of the Metercam. See Fig. 2.4.

2. Switch on the tester

Switch on the MT-1/NT5. The remote self-tests and a display appears which indicates the Form and the TA of the meter.

```

METER TYPE
FM: 4S   TA:2.5
<ENTER>  <←→>

```

If the Form and the TA displayed are correct as shown above, press **Enter**, otherwise use arrow keys to change them.

3. Disk Detection

Once the remote has detected the presence of the Metercam a load is applied automatically to the meter to spin the disk. The Metercam starts the scanning process to detect the position of the meter disk. The red LED turns on when the scanning starts. The green LED turns on when the Metercam has found the position of the disk. Finally, the red LED turns off when the black flag is found on the disk, and turns on only when the black flag passes in front of the Metercam.

METERCAM V2.1 INSTALLED Scanning ..?..	METERCAM V2.1 INSTALLED Disk Found
--	--

Once the Metercam has found the black flag, a quick test is done automatically to estimate the Kh of the meter. If the estimated Kh found is already stored in the remote, it is chosen to do the test. Otherwise, you can accept or change the estimated Kh and store it in the remote. If for some reason the Kh does not match the meter's, you can always change the Kh manually.

4. Initialization

Press the **Mode** key and choose **User-defined**.

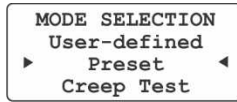

Press **Mode** again to come back to the test menu.

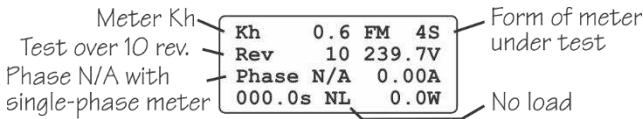

In the test menu, check that the Kh is 0.6 and the number of revolutions for the test is 10. With a single-phase meter, the phase is not displayed.

5. Loading and Testing

Press **HL**, the load current will increase to 2.5A and the disk will start to rotate. Press **Start/Stop** to initiate the test. The measurements will begin only when the Metercam has picked up the black flag and starts to count the disk revolutions. At this precise time, the MT-1//NT5 starts to measure the energy that passes through the meter. You will hear a double beep indicating that the test has begun.

In addition to the test parameters appearing on the display, the operator can see the voltage and current applied to the meter, the chronometer and the cumulated energy registered by the watt-hour standard. A typical running test display is shown below:

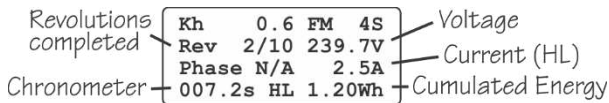

On this display, the internal watt-hour standard of the MT-1/NT5 shows that it has registered up to now 1.20Wh (voltage x load x time). When calculating Wh, time is expressed in hours.

6. Test Results

The watt-hour measurement period ends automatically after the 10th disk revolution is completed i.e. when the Metercam has registered its 10th revolution. Then the load is removed automatically to stop the disk and test results are displayed. A typical test result is shown below:

The test result shows this meter has a percentage registration of 99.91% under a 2.5A load, therefore slightly slow by -0.09%. If you want to repeat the test at PF or LL, press **Reset** and start at Step 5 with the new load.

Now, you can save your test results by pressing the **Reset** key as shown below:

TEST	REPORT
Mt-1	6.0054Wh
Meter	6.0000Wh
HL:	99.91%

Energy measured by the MT-1/NT4

Energy measured by the meter (Kh x rev)

Accuracy at HL

Press **PF** to start the saving procedure. If you do not want to save these results, then press **LL**. Data Logging operations are detailed on page 20.

Storing data for this test?	
<LL>No	<PF>Yes

Temporary Configuration Menu

During a test, you might wish to bring a temporary change to the **Setup** or **Load** menus. For example, you are facing a meter with a Kh that does not appear in the Kh Table. Another example, you want to set a load of 25A instead of 30A with the HL key.

By following the procedures described below, it is possible to bring one or many changes. Please note that the temporary configuration is lost when the remote control is powered off.

If you wish to bring a permanent change, you must access the **Configuration Menu**, described in the chapter 5. This menu is more complete and versatile.

Adding a new Kh

From the main menu, press and hold **Kh** at least 2 seconds; A small menu appears. Type the new Kh with the keypad and the arrows. The maximum value for Kh is 50.00000.

In the case of a Kh with a fraction, type the fraction in decimal form. For example, a Kh of $6\frac{2}{3}$ is written as 6.66666; a Kh of $10\frac{3}{4}$ is written as 10.75000, etc.

Adding a new Rev

From the main menu, press and hold **Rev** at least 2 seconds; A small menu appears. Type the new Rev with the keypad and arrows. Acceptable whole values for Rev range from 1 to 99 inclusively.

Changing the Load

From the main menu, press and hold **HL**, **PF** or **LL** at least 2 seconds; A small menu appears. Type the new current load with the keypad and arrows. The key takes in temporarily the new load value. **Note:** A meter must be inserted in MT-1/NT5 socket to change the load.

Chapter 4

Advanced Functions

In addition to the test modes available to check Wh meters, the MT-1/NT5's handheld remote comes with advanced functions which are **Record Viewer**, **Line Monitor** and **Creep Test**.

Record Viewer

To view a saved result, use the Record Viewer in the remote control. In the Mode Menu, press the **up/down** arrow keys to select the Record Viewer. The following display appears:

```

MODE SELECTION
▶ Record Viewer◀
  Creep Test
  Line Monitor
  
```

Press **Enter** to access. A description and the navigation keys of the Record Viewer are described below.

```

R00001      1/23▼
2011/05/21 14:44
METER ID:
>18418531
  
```

R00001: This is a permanent record number (with the prefix R) and cannot be modified nor deleted. This number is incremented after saving a test. It starts at 00001 up to 99999, then restarts at 00001.

1/23: This number shows the number of test results currently stored in the non-volatile memory.

Navigation Functions:

UP/DOWN arrows:	Line up/down through the results of a test.
SHIFT + UP/DOWN:	Page up/down through the results of a test.
LEFT/RIGHT arrows:	Moves to another test.
SHIFT + Left arrow:	Backs to the first test in memory.
SHIFT + Right arrow:	Goes to the last test in memory.
Clear key:	Deletes record appearing on the display.
SHIFT + Clear key:	Deletes all records.

Line Monitor Test

The line monitor tests analyzes the input voltage in order to determine statistically the voltage and frequency fluctuations.

In the Mode Menu, press the **up/down** arrows to select Line Monitor then press **Enter** to access. The following display should appear:

LINE MONITOR	
Frequency	59.99
Voltage	239.9
Samples	0

Press **Start/Stop** to start sampling. You can read on the display the instantaneously line frequency and the line voltage.

LINE MONITOR		
Frequency	59.98	← Frequency and Voltage
Voltage	239.8	
Samples	26	← # Samples

On the display on line 4 the number of samples increases with time. A beep is heard each time a new minimum or maximum is detected.

To end the test, press **Start/Stop**. On the display, you can see the Minimum, Maximum and Average values of the line frequency and voltage during the sampling period.

	Freq.	Volt
Min:	59.98	239.2
Max:	60.02	240.6
Avg:	60.00	239.9

Creep Test

A meter is considered to creep if, with the load wires removed (no current) and nominal voltage applied to the meter, the disk makes one complete revolution in less than 10 minutes. With solid-state meters, no more than 1 pulse must be measured per quantity at 0.00A (no current).

Note: The MT-1/NT5 uses a closed-link arrangement on the meter's load terminals and can not be opened. However, in creep test mode, the internal current synthesizers are set to 0.00A (no current), thus simulating an open circuit.

In the Mode Menu, press **up/down** arrows to select Creep Test then press **Enter** to access. The following display should appear:

```

CREEP TEST
Timer:      05:00
<START>    <↔>
    
```

The **up/down** arrow keys allow to set the timer for the Creep Test. There are three-time intervals available: 5, 10 and 15 minutes.

When ready, press the **Start/Stop** key to begin the test.



Warning!

The deadfront safety is disabled when this test is initiated. Do not remove the meter during this test, line voltage is applied on the upper front jaws! A flashing warning message is displayed during this test.

```

CREEP TEST
Timer:      04:27
WARNING: Dead-
front Disabled
    
```

Warning!

When the creep test ends, the following message appears and deadfront safety is re-enabled. If the disk has not completed a full revolution or received more than one pulse during a test, that means the meter does not creep.

```

CREEP TEST
Timer:      00:00
Creep Test Ended
    
```

Chapter 5

Configuration

The MT-1/NT5 comes with manufacturer default operation parameters that can be easily changed according to your needs using the Configuration Menu. It includes many sub-menus to modify operation parameters stored in the non-volatile memory of the handheld remote control. The available sub-menus are described below.

Sub-Menus	Description
Kh Edition	Adds, changes or deletes a Kh value
Kh Default	Assigns the Kh by default to each of the forms
Rev Edition	Adds, changes or deletes a Rev
Load Edition	Defines a new TA Load percentage
Preset Edition	Defines a new sequence of consecutive tests
General Edition	Initializes parameters such as: <ul style="list-style-type: none"> • Rev by default • Mode by default • Preset by default • Report Format (Error/Registration) • Time/Test (Min. duration time per test point) • Language selection • Warning when results are over a predetermined percentage • AutoKh • Sensus Warning • Enable Data Log • Enable Auto Save mode • Time and Date
Factory Default	Manufacturer's default Configuration
Accuracy Test	Tests the MT-1/NT5's internal watt-hour standard against a NIST traceable standard
User Calibration	Calibration by the user ($\pm 0.05\%$ maximum shift allowed from factory calibration, step $\pm 0.001\%$).

How to Access the Configuration Menu

To access the **Configuration** menu, follow these steps:

1. Press and hold **Reset** on the remote while turning on the MT-1/NT5.
2. After a few seconds, the configuration menu will appear.
3. Release **Reset**. The configuration menu lets you access one of the nine sub-menus.

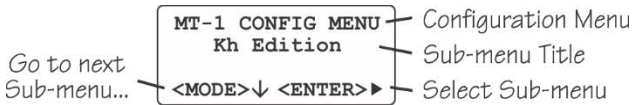

The title of the sub-menu is displayed on the second line.

4. To move from one sub-menu to the next, press **Mode**.
5. To access a sub-menu, press **Enter** then follow the new indications appearing on line 4 of the sub-menu.
6. To return to the configuration menu, press **Reset** only once.
7. To exit the configuration menu, press **Reset** twice. If there has been a change in a sub-menu, a saving menu appears.

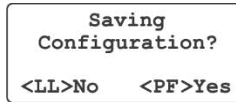

8. Press **PF** to save the changes or **LL** to discard any changes. A Beep is heard when data is saved in the non-volatile memory. Afterwards, the remote comes back to the Main Menu.

Description of the Sub-Menus

This section describes and shows how to use each of the sub-menus. Examples are provided at the end of this chapter.

Kh Edition Sub-Menu

With this sub-menu, you can modify the content of the Kh Table. The table already contains eleven Kh: 0.3, 0.6, 1.0, 1.2, 1.8, 3.6, 6.0, 7.2, 12.0, 14.4, 21.6 and 36.0. You can add, change or delete one or many Kh in the table which can contain a maximum of eighteen Kh. The maximum value that can be given a Kh is 50.00000.

In the case of a Kh with a fraction, use decimals. For example, a Kh of $6\frac{2}{3}$ is written in as 6.66666.

Procedure

1. In the **Configuration** menu, press **Mode** to reach the 'Kh Edition' sub-menu appearing on the second line of the display.
2. Press **Enter** to access. The following sub-menu should appear:



3. Use the arrow keys to edit the Kh value. The **up/down** arrow keys allow to increase or decrease the value under the cursor. The **left/right** arrow keys allow to move the cursor.
4. To go to the next Kh press **Mode**.

Adding, Changing, Deleting a Kh

To add a Kh that does not exist in the table:

1. Go to where the Kh is at zero '00.00000'.
2. Type the new Kh.

To change an existing Kh:

1. Go to where the Kh to be replaced appears.
2. Type the new Kh.

To delete a Kh in the table:

1. Go to where the Kh to be deleted appears.
2. Enter the value 00.00000. **Note:** 7.2 value cannot be deleted.

Kh Default Sub-Menu

With this sub-menu, you can assign a default Kh according to the Form of the meter. The Kh default is assigned only when the pickup is not used. With a pickup, there is no Kh by default, the Kh is estimated regardless of the Form of the meter.

Procedure

1. In the **Configuration** menu, press **Mode** to reach the 'Kh Default' sub-menu appearing on the second line of the display.
2. Press **Enter** to access. The following sub-menu should appear:

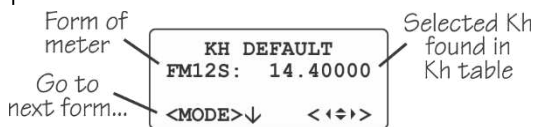

3. Use the arrow keys to go up and down the Kh table and choose a different Kh assigned to the form currently displayed.
4. To go on the next Form, press **Mode**.

Rev Edition Sub-Menu

With this sub-menu, you can modify the content of the Rev table. The table already contains seven Rev: 1, 2, 5, 10, 20, 30 and 50. You can add, change or delete one or many Rev in the table which can contain a maximum of ten Rev. The Rev value must be between 1 and 99.

Procedure

1. In the configuration menu, press **Mode** to reach the 'Rev Edition' sub-menu appearing on the second line of the display.
2. Press **Enter** to access.
3. The following sub-menu should appear:

KH EDITION	
1/18:	0.30000
<MODE>↓	<←→>

4. Use the arrow keys to change the value. The **up/down** arrow keys allow to increase or decrease the value under the cursor. The **left/right** arrow keys allow to move the cursor.
5. To go to the next rev press **Mode**.

Adding, Changing, Deleting a Rev

To add a Rev that does not exist in the table:

1. Go to where the Rev is at zero '00'.
2. Type the new Rev.

To change an existing Rev:

1. Go to where the Rev to be replaced appears.
2. Enter the new Rev.

To delete a Rev in the table:

1. Go to where the Rev to be deleted appears.
2. Type the value '00'. **Note:** You cannot delete the '10' Rev.

Load Edition Sub-Menu

With this sub-menu, you can assign for each of the 3 Load keys (LL, PF and HL) a percentage from 10 to 100% of the TA (Test Ampere). By default, **HL** and **PF** are set at 100% of the TA and **LL** is set at 10% of the TA. Example: If the TA of the meter is 30A, then **HL** is set to 30A, **PF** is set to 30A (current 60° behind voltage) and **LL** is set to 3A.

Procedure

1. In the **configuration** menu, press **Mode** to reach the 'Load Edition' sub-menu appearing on the second line of the display.
2. Press **Enter** to access. The following sub-menu should appear:

LOAD EDITION	
HL:	100% of TA
<MODE>↓	<↕>

3. The **up/down** arrow keys allow to increase or decrease the value under the cursor. The **left/right** arrow keys allow to move the cursor.
4. To go to the next Load Press **Mode**.

Changing a Load

- Choose the load key you want to change with the **Mode** key then change the percentage of the TA you want. Repeat this operation if necessary for each one of the three loads: **HL**, **PF** and **LL**.

Preset Edition Sub-Menu

This sub-menu has four parameters. The first three parameters define the sequence of the test. The sequence for electromechanical meters is the number of revolutions to be done by the disk at HL, PF and LL respectively. By default, the sequence is 10 revs at HL, 5 revs at PF and 1 rev at LL. The number of Rev at HL and at LL cannot be less than 3 and 1 respectively. If the number of Rev at PF is set at 0, the test at PF is skipped.

Note that for solid-state meters the number of revolutions is replaced by a minimum time per test point. By default, the minimum time is 20sec. This can be changed using the configuration menu. Again, if PF is set at 0, the test is skipped.

The last parameter defines the ratio used in calculating the weight of a test report. By default, the ratio is 4:1. The calculation of the weight is done independently of the number of revolutions at HL and LL.

Procedure

1. In the configuration menu, press **Mode** to reach the 'Preset Edition' sub-menu appearing on the second line of the display.
2. Press **Enter** to access. The following sub-menu should appear:

PRESET EDITION	
HL:	10
<MODE>↓	<↔>

3. The **up/down** arrow keys allow you to increase or decrease the whole number under the cursor. The **left/right** arrow keys allow you to move the cursor.
4. To go to the next parameter, press **Mode**.

By pressing the **Mode**, you reach the second parameter that determines the number of revolutions to be done at PF and so on.

By pressing the **Mode** key again, you reach the third parameter that determines the number of revolutions to be done at LL.

Finally, by pressing the **Mode** key again, you reach the fourth parameter that determines the ratio used in calculating the weight of a test. With a ratio of 4:1, the formula is $(4HL+1LL)/5$. With a ratio of 2:1, the formula is $(2HL+1LL)/3$ and so on.

General Edition Sub-Menu

This sub-menu includes several factory default settings. You can change these default settings according to your needs and specifications.

Procedure

1. In the configuration menu, press **Mode** to reach the 'General Edition' sub-menu appearing on the second line of the display.
2. Press **Enter**. The following sub-menu should appear:

```
GENERAL  EDITION
Rev Def:   10
<MODE>↓  <←→>
```

The first setting shown is 'Rev Def:'.

3. To go to the next setting press Mode. These settings are described below.

Settings	Brief Description
Rev Def:	Rev selected at power on. Press the up/down arrow keys to select another one contained in the Rev table. Default is 10.
Mode Def:	Mode selected at power on. Press the up/down arrow keys to toggle between MAN/USR and TRK/PRE Modes. Default is TRK/PRE.
Preset Def:	Preset Mode selected at power on. Press the up/down arrow keys to toggle between Preset-quick and Preset-full. Default is Preset-quick.
Report:	Percentage format report. Press the up/down arrow keys to toggle between % error or % registration. Default is % registration.

- Time/Test: Minimum duration time by test point for solid-state meter. Press the **up/down** arrow keys to set the duration time. Minimum time is 10 seconds and maximum time is 120 seconds. Default is 20 seconds.
- Language: Selection of language. Use the **up/down** arrow keys to toggle between English, Spanish and French. Default is English.
- Warning: A warning message is displayed when the test result is over a predetermined percentage. Use the **up/down** arrow keys to set the percentage. Available percentages are 1%, 1.5%, 2%, 3%, 5% and 10%. Default is Warning disabled.
- AutoKh: Automatic detection of the Kh value. Use the **up/down** arrow keys to enable or disable this option. By default, it is enabled.
- Sensus Warning: Displays a warning after detection of a 3S meter. At first, a question is asked if this is a Sensus meter. By answering NO to the previous question, the test continues. If YES, another question is asked if you have an adaptor. If YES, the test continues. If NO, the test stops to prevent damage to the Sensus meter. This function can be enabled or disabled by using the **up/down** arrow keys. By default, it is enabled.
- Datalog: Data Logging operations take place after a successfully test. Use the **up/down** arrow keys to enable or disable. Default is enable.
- Auto Save: It is to save the results automatically to the handheld. It can be disabled or saves after 1, 2, 5 or 10 seconds after the completion of the test. By default, this function is disabled. It will not auto save if the function data logging is disabled.
- Time and Date: Set the Time and the Date in the Remote. Use the **up/down** and **left/right** arrow keys to change time or date.

Factory Default Sub-Menu

With this sub-menu, you can revert to factory configuration when you first purchased the MT-1/NT5 except for the language of the display and the User Calibration factor. User Calibration is stored in the non-volatile memory of the socket and not in the remote.

Procedure

1. In the configuration menu, press **Mode** to reach the 'Factory Default' sub-menu appearing on the second line of the display.
2. Press **Enter** to access. The following sub-menu should appear:

```
Restore
Factory Default?
<LL>No   <PF>Yes
```

3. Press **PF** to revert to the factory configuration.
or
Press **LL** to keep the actual configuration.

Configuration Examples

The following examples will give you a good idea of how the Configuration Menu works.

Adding a New Kh

Kh: 6-2/3 (6.66666 decimal form)

1. Access the **Configuration** menu.
2. Press **Enter** to access to the 'Kh Edition' sub-menu:

```
KH EDITION
1/18:    0.30000
<MODE>↓  <←→>
```

3. Press **Mode** eleven times to go to Kh no. 12 (12/18).
4. Press the **right** arrow to move the cursor to the right.
5. Press **6** on the keypad six times to write 06.66666.

```
KH EDITION
12/18:   06.66666
<MODE>↓  <←→>
```

- Once the right Kh is written in, press **Reset** twice. The Saving Menu appears. Press **PF** to save the new Kh in non-volatile memory. The new Kh is now recorded in the table.

Changing Preset Default Sequence

Change the default Preset Mode sequence to 12 revs at HL, 4 revs at PF and 2 revs at LL and a 1:1 weighted ratio, (1HL+ 1LL)/2.

- Access the **Configuration** menu.
- Press **Mode** four times to reach the 'Preset Edition' sub-menu appearing on the second line of the display. Press **Enter**, to access HL preset. The following display should appear:

```

PRESET EDITION
HL:           10
<MODE>↓     <←→>
    
```

- Press the **left** arrow key to move cursor and type the number 12 using the keypad instead of 10 revolutions at HL.
- Press **Mode** to access PF preset. Press the **left** arrow key to move cursor and type the number 4 using the keypad instead of 5 revolutions at PF.

```

PRESET EDITION
HL:           12
<MODE>↓     <←→>
    
```

- Press **Mode** to access LL preset. Press **left** arrow key to move cursor and type the number 2 using the keypad instead of 1 revolution at LL.

```

PRESET EDITION
PF:           04
<MODE>↓     <←→>
    
```

- Press the **Mode** key again to reach the 'Weight' sub-menu. Type the number 1 using the keypad instead of 04. The ratio is now 1:1.

```

PRESET EDITION
LL:           02
<MODE>↓     <←→>
    
```

- Once the change done, press **Reset** twice. The Saving Menu appears:

```
PRESET EDITION
Weight:      01
<MODE>↓    <←→>
```

Press **PF** to save the change in non-volatile memory or **LL** to discard changes.

```
      Saving
      Configuration?
<LL>No  <PF>Yes
```

Chapter 6

Automatic Accuracy Test

MT-1/NT5's accuracy can be checked against a **NIST** traceable standard using the following automatic test procedure. MT-1/NT5's accuracy is tested on 6 different current test points: 1.5, 3.0, 5.0, 15.0, 30.0 and 50.0A at both 1 and 0.5 lag power factors. It can be done using a AC power source at either 120V or 240V.

Equipment Required

- A primary or secondary electronic watt-hour standard traceable to NIST, with an output BNC port of 10 μ Wh or 20 μ Wh per pulse. The standard must have at least 1 isolated current input port of a minimum capacity of 50A with autoranging capability. The standard must have a typical precision of 0.01% or better.
- The Probewell Single-Phase Accuracy Testing Kit (ATK-4). The Kit includes the following items:
 - A pulse interface (PW-8967), a BNC coaxial cable and a Probewell extension cable RJ12 type connection.
 - An accuracy test jack. Use this test jack only with MT-1/NT4 and MT-1/NT5.
- A laboratory stabilized and isolated AC power source with fundamental waveform selectable 120V or 240V \pm 5%, 58~62Hz, rated at **least 150VA**.

NOTE: A laboratory stabilized and isolated AC power source is preferred rather than a small isolated line transformer or autotransformer. Such small transformer could generate severe harmonics and voltage fluctuations which could cause small additional measuring errors. **Always fuse** the power leads going to the rear tabs 1 & 2 of MT-1/NT5 with a quick action 1A fuse type. The power leads and fuses are not provided with the ATK-4.



CAUTION!

This procedure involves high voltage, AC line-connected potential once the power is on. Use extreme caution in working with and making connections to this circuit. **REPEAT:** This circuit contains dangerous, AC line-connected high voltage potential. Use caution.

Procedure

1. Connect the power leads from the AC power source to tabs 1 and 2 located at the back of MT-1/NT5 with the help of insulated alligator clips. See the following figure. Always leave the Form Selector switch in 1S/2S position (left).

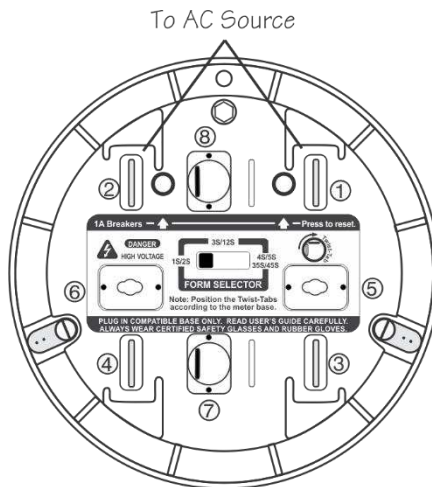

Fig. 6.1 – Power Hook Up

2. Install the test jack on top of the MT-1/NT5, the current and potential wires between the MT-1/NT5 and the standard while respecting the polarity (see Fig. 6.2). As for connecting the Aux. Power ports, please refer to the Standard's manufacturer for details.

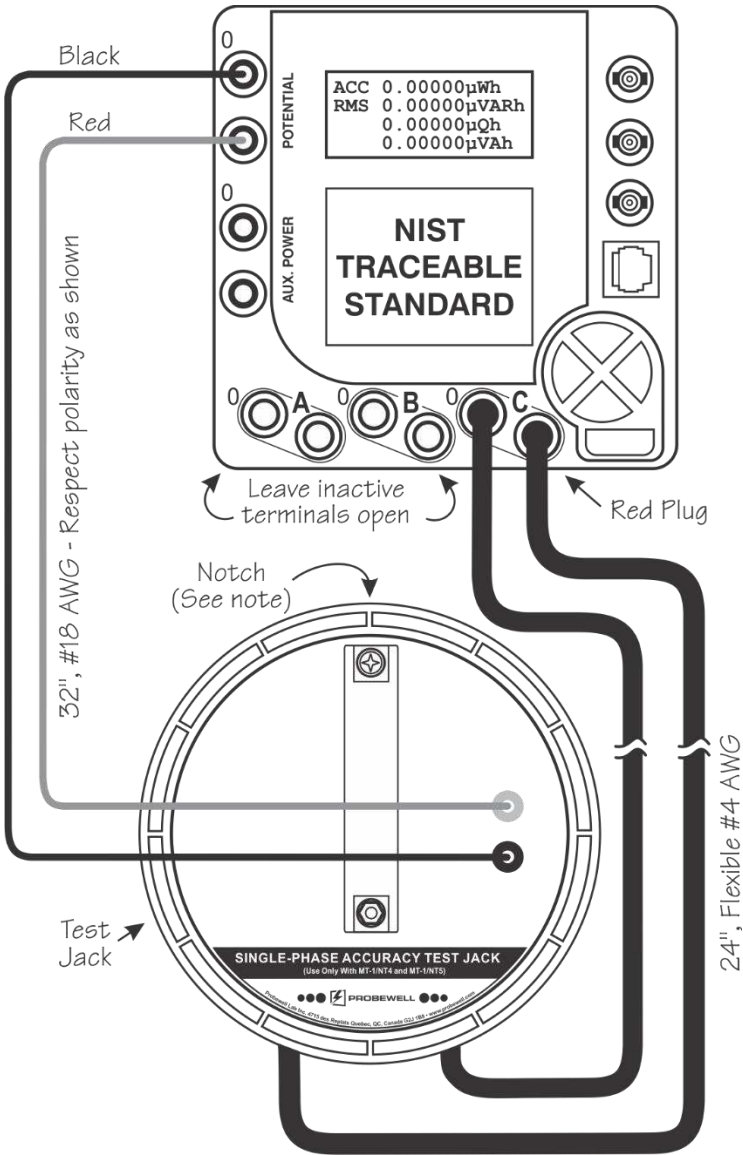

Fig. 6.2 – Connection of Test Jack to the Standard

Note: When you are ready to remove the test jack, insert a large flat screwdriver in the notch located on the side of the rim to pry it out of the Test Socket.

3. Connect the coaxial cable from the input pulses BNC connector on the pulse test interface to the output pulses BNC connector of your standard. Then, connect the MT-1/NT5 extensible cable from the RJ12 port 1 to the MT-1/NT5 socket. Connect the other extensible cable from the RJ12 port 2 to the handheld. The pulse test interface is powered by the handheld itself. A red led indicates the presence of power.

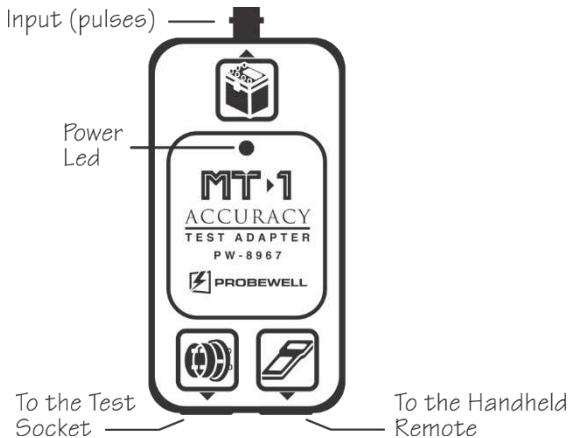

Fig. 6.3 – ATK pulse interface

4. Once all cables in place, while pressing and holding the **Reset** Key of the handheld turn on the power source and MT-1/NT5. After a few seconds, the Configuration Menu will appear:

```
MT-1 CONFIG MENU
Kh Edition
<MODE>↓ <ENTER>▶
```

5. Press **Mode** seven times to access the Accuracy Test menu appearing on the second line of the display. The following display should appear:

```
MT-1 CONFIG MENU
Accuracy Test
<MODE>↓ <ENTER>▶
```

- Press **ENTER** to access the Accuracy Test Menu. The following Menu must appear:

```

ACCURACY TEST
Ref:10uWh PF:1.0

<START> <←→>
    
```

- By default, the pulses are set at 10 μ Wh and PF at 1.0. Use the arrows to select the pulse rate (10 or 20 μ Wh) and the power factor (PF) which can be either 1 or 0.5 lag.

```

ACCURACY TEST
Ref:10uWh PF:1.0

<START> <←→>
    
```

- Press **Start** to begin the test. The MT-1/NT5 is checking wiring setup, doing auto-scaling, etc.

```

000.0s      UNITY
MT-1      0.00000Wh
REF.      0.00000Wh
Waiting .....
    
```

Remark: If the cables are not properly connected an error message will appear. For safety, turn off both the AC power source and the MT-1/NT5. Check all the connections (polarity) and start steps 4 to 8 again. Do not forget to set the standard in **Wh** (watthour) mode. Make sure the coaxial cable is connected between the standard's output pulse and the input pulse test interface.

- After a few seconds, the test begins. The second line displays the energy recorded by MT-1/NT5. The third line displays the energy measured by the standard. The fourth line shows the current test point and the % error that converges towards the final result. Each test point takes 20 seconds.

```

003.6s      UNITY
MT-1      0.35711Wh
REF.      0.35712Wh
T1: 1.5A -0.003%
    
```

10. Once each test point has been tested a single beep is heard a few seconds prior to the end of that current test point. The result is displayed for a few seconds after each test point.

020.0s	UNITY
MT-1	1.99725Wh
REF.	1.99720Wh
T1:	1.5A +0.003%

11. Once the entire 6 test points are completed, a triple beep is heard and the first 3 current points are displayed giving the accuracy for each.

ACCURACY	REPORT
T1:	1.5A +0.003%
T2:	3.0A +0.002%
T3:	5.0A +0.003%

12. Press **Mode** key and the next 3 results are displayed.

ACCURACY	REPORT
T4:	15A +0.004%
T5:	30A -0.003%
T6:	50A -0.001%

13. Press **Mode** again and a summary report showing the accuracy of MT-1/NT5 appears on the display.

ACCURACY	REPORT
Average	+0.001%
Maximum	+0.004%
Minimum	-0.003%

14. If the average error is within the tolerance of the MT-1/NT5's Wh standard, it means that it is within specifications and it does not need to be calibrated in shop. The MT-1/NT5's internal Watthour Standard does not contain potentiometers or other types of screw adjustment that could become unstable with time. This means that MT-1/NT5's accuracy should not change much over years. However, if MT-1/NT5 needs to be recalibrated, follow the User Calibration procedure found on the next page.

User Calibration

Description

With this sub-menu, you can change the calibration of MT-1/NT5. It is used when you need MT-1/NT5 calibration to correspond exactly to a NIST traceable standard. The maximum percentage deviation allowed in relation with the MT-1/NT5 factory calibration is $\pm 0.05\%$, by steps of 0.001% . By default, the deviation is $+0.000\%$ (nil). The User Calibration correction factor is stored in the non-volatile memory of the MT-1/NT5 socket.

Procedure

1. Write down the average error result given by the accuracy test. Exit the Accuracy Test Menu by pressing twice on **Reset**, then press **Mode** to call the 'User Calibration' menu and press **ENTER** to access. The following sub-menu should appear:

```

USER CALIBRATION
+0.000%
<MODE>↓   <←→>
  
```

To change calibration, use the **up/down** arrows to decrease or increase the deviation percentage of MT-1/NT5.

2. When the average error is greater than (+)0.000%, it means that MT-1/NT5 measures more energy than it should and must be slowed down by that value. Therefore, you subtract the "+value".

When the average error is smaller than (-)0.000%, it means that MT-1/NT5 measures less energy than it should and must be speeded up by that value. Therefore, you add the "-value".

Example 1: If the average error is +0.028%, and the value in the sub-menu is -0.005%, you subtract 0.028% and the value shown on the display will become -0.033% [-0.005% - 0.028%].

Example 2: If the average error is +0.028%, and the value in the sub-menu is +0.035%, your new value would be +0.007% [+0.035% - 0.028 %].

Example 3: If the average error is -0.026%, and the value in the sub-menu is -0.035%, your new value would be -0.009% [-0.035% + 0.026%].

Example 4: If the average error is -0.029%, and the value in the sub-menu is +0.008%, your new value would be +0.037% [+0.008% + 0.029%].

3. Once the new value is entered, press **Reset**. You are then asked to enter the current date. The following should appear:



4. Once the date is set (using the editing keys), press **Reset** twice and the Saving Menu appears. Press **PF** to save the new value in the non-volatile memory of the socket. MT-1/NT5 is now calibrated against your traceable Standard.

Note:

At power on, the message Cal yyyy/mm/dd appears on the display. Without parentheses, the date indicates when the MT-1/NT5 unit was calibrated by Probewell before shipment. When the message is shown between parentheses, it means that MT-1/NT5 has been calibrated according to your specifications in your own shop.

A booklet containing more details is provided with the Accuracy Testing Kit.

Appendix A

Specifications

General

Physical Dimensions (HxLxD)

Test Socket (Diam. x D)	6.9" x 7.7" (175 x 195 mm)
Remote Control	8.3" x 3.9" x 1" (210 x 100 x 26 mm)
Carrying Bag	11" x 11" x 8" (280 x 280 x 203 mm)

Weight

Test Socket	5.7lb (2.60 kg)
Remote Control	0.6 lb (0.28 kg)
Overall with Carrying bag	8.2 lb (3.72 kg)

Temperature

Operation	-4 to 140 °F (-20 to 60 °C)
Storage	-4 to 140 °F (-20 to 60 °C)

Optional Test Accessories

MT-1/CAM-2	Metercam (digital camera disk sensor)
MT-1/PUL-3	Optical pickup for electronic meters
MT-1/ATK-4	Accuracy Testing Kit
MT-1/LOG-1	Software and hardware kit for data logging storage

Handheld Remote Control

Input

Voltage	12VDC \pm 10%
Consumption	2.5W (maximum)

Display

LCD, 4-line x 16-character

Keypad

24-key, tactile

Serial communication port

Full-duplex RS-232

Data Storage

Flash	Provision for firmware upgrades
EEPROM	User setup and data logging storage

Time

Real-time clock	Time and date stamp
-----------------	---------------------

Test Socket Adapter

Input

Voltage	100-600VAC
Line Frequency	58-62Hz
VA Consumption	75VA (maximum)
Bypass Circuit	200A (standard)
Circuit Breakers	1A, resettable

Serial communication port Full-duplex RS-232 (isolated)

Forms of Meter

MT-1/NT5	1S, 2S, 3S, 4S, 5S(35S), 12S and 45S
----------	--------------------------------------

Synthesized Adjustable Current (unity and 0.5 lag Power Factor)

MT-1/NT5	0.25 to 50A
----------	-------------

Voltage Applied to Meter

Line-voltage protected by two 1A circuit breakers and activated only when meter is inserted. Voltage is current limited.

Wattour Standard Accuracy (unity and 0.5 lag Power Factor)[†]

Typical	±0.02%
Maximum guaranteed	±0.05%
Influence affecting accuracy	None

Multimeter Accuracy

RMS Voltage	±0.05%, maximum
RMS Current	±0.05%, maximum
Frequency	±0.01%, maximum

[†] The MT-1/NT5's internal wattour standard is calibrated using a primary standard traceable to NIST and comes with a complete calibration report certifying measurement accuracy over its entire operating range on 36 points. Test accuracy can be done using a primary or secondary standard and the automatic Accuracy Testing Kit (ATK-4). The calibration of the MT-1/NT5's wattour standard can be changed using the User Calibration menu. However, User Calibration is limited to ±0.05% (steps of ±0.001%) from the factory calibration. User Calibration is stored in the non-volatile memory of the socket. The socket contains a unique internal number that identifies its internal wattour standard.

Appendix B

Compatible Meter Forms

This Appendix refers to all meter Forms compatible with the MT-1/NT5. For each meter form, the electrical service is shown at the top left and an internal schematic of the meter installed at the top right. Wiring that connects the meter to the line and load is also shown. Before proceeding to a field test, make sure that the connections to the socket for a given Form are similar to those shown hereafter. The symbols used are described here:

Circuit



Meter & Meter Socket

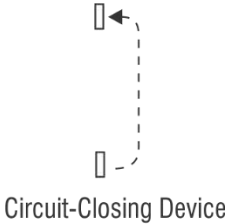

Instrument Transformer



Form 1S

Single-Phase Two-Wire

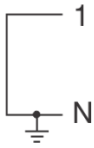

120 or 240 volts

Form 1S

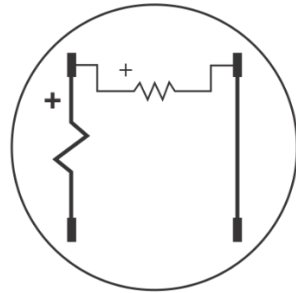

Meter Internal Wiring
(Front View)

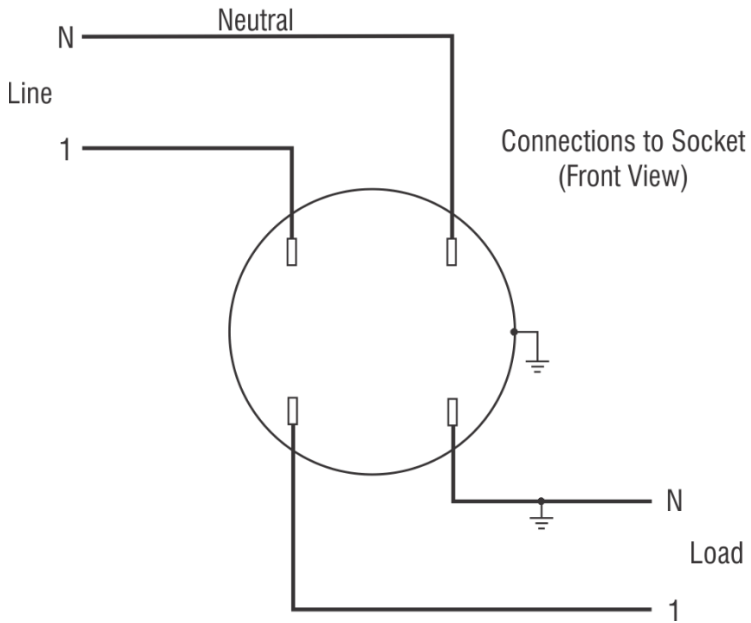

Form 2S

Single-Phase Three-Wire

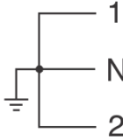

120 volts line-to-neutral
240 volts line-to-line

Form 2S

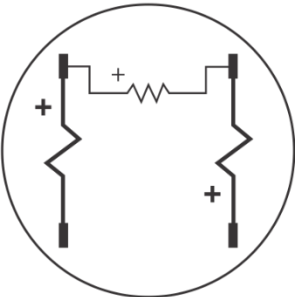

Meter Internal Wiring
(Front View)

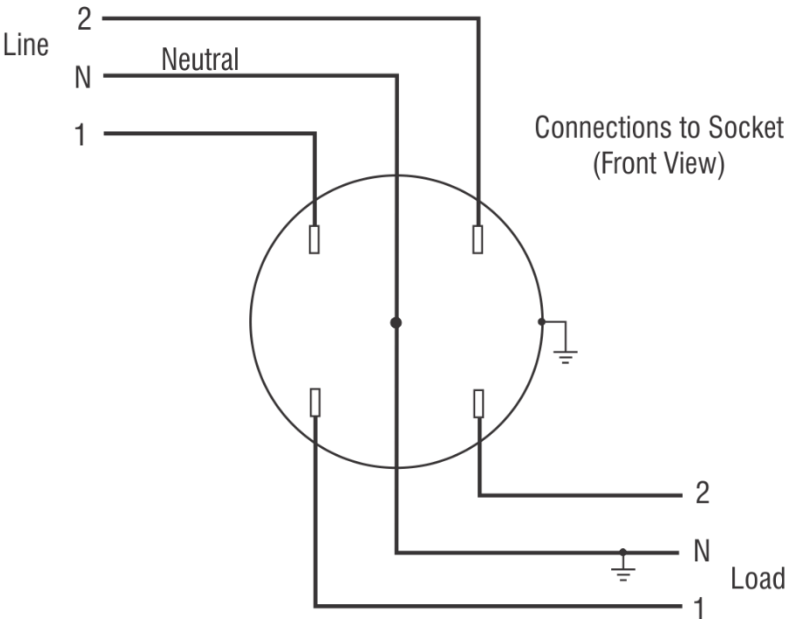

Form 3S

Single-Phase Three-Wire With CT

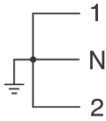

120 volts line-to-neutral
240 volts line-to-line

Form 3S

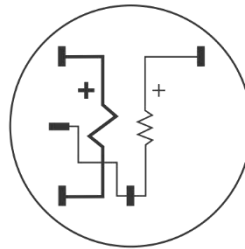

Meter Internal Wiring
(Front View)

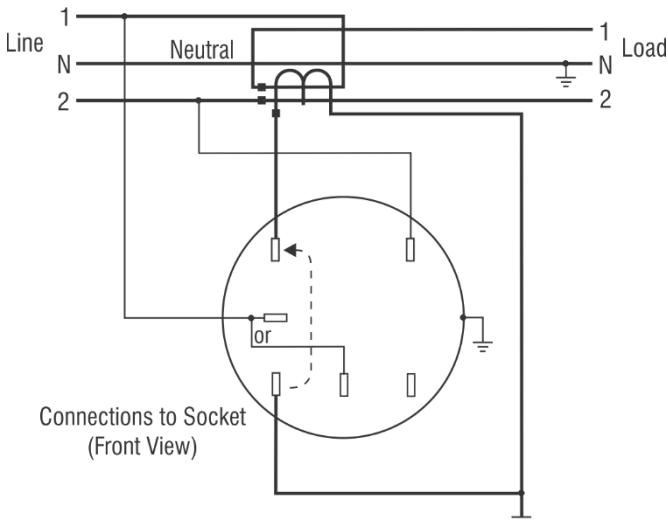

Form 3S single-phase, 120 volts two-wire with CT is also compatible.

Caution: Never open a circuit-closing device if current is flowing in the CT primary. Serious personal injury may result.

Note: Because of higher impedance, some 3S, 240V of older design will not reach full HL when tested with the MT-1/NT5. However, it will test as high as it can.

Note: Installations with double-primary CT (not shown) are also compatible. Installations with PT (Potential transformer) are not compatible.

Caution: Sensus 3S meter requires an adapter before testing with the MT-1/NT5.

Form 4S

Single-Phase Three-Wire Two CTs

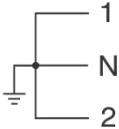

120 volts line-to-neutral
240 volts line-to-line

Form 4S

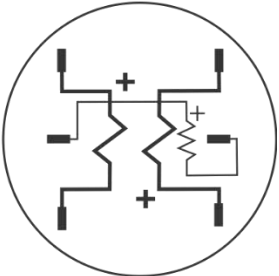

Meter Internal Wiring
(Front View)

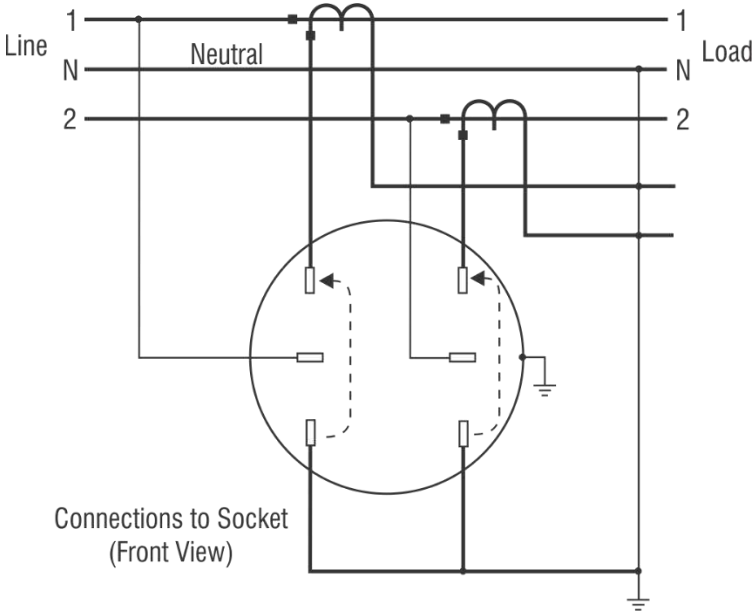

Caution: Never open a circuit-closing device if current is flowing in either CT primaries. Serious personal injury may result.

Note: Installations with PT (Potential transformer) are not compatible.

Form 5S (N) Network with two CTs

Three-Wire Network With Two CTs

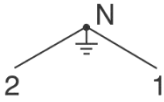

120 volts line-to-neutral
208 volts line-to-line

Form 5S

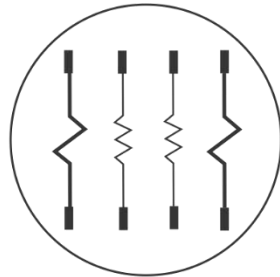

Meter Internal Wiring
(Front View)

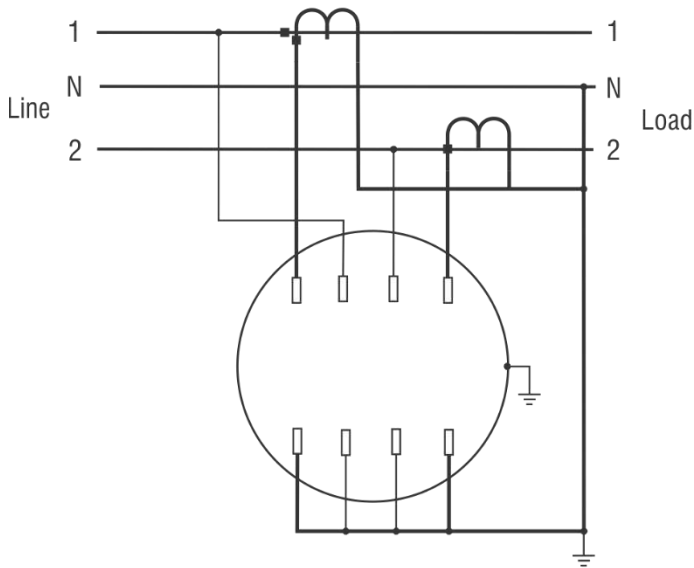

Connections to Socket
(Front View)

Form 5S Delta with two CTs

**Three-Phase
Three-Wire Delta
With Two CTs**

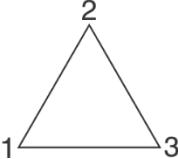

240 volts line-to-line
or 480 volts line-to-line
or 120 volts line-to-line

Form 5S

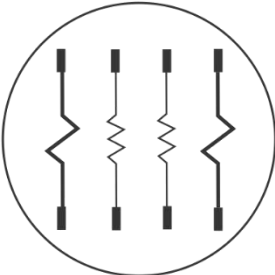

Meter Internal Wiring
(Front View)

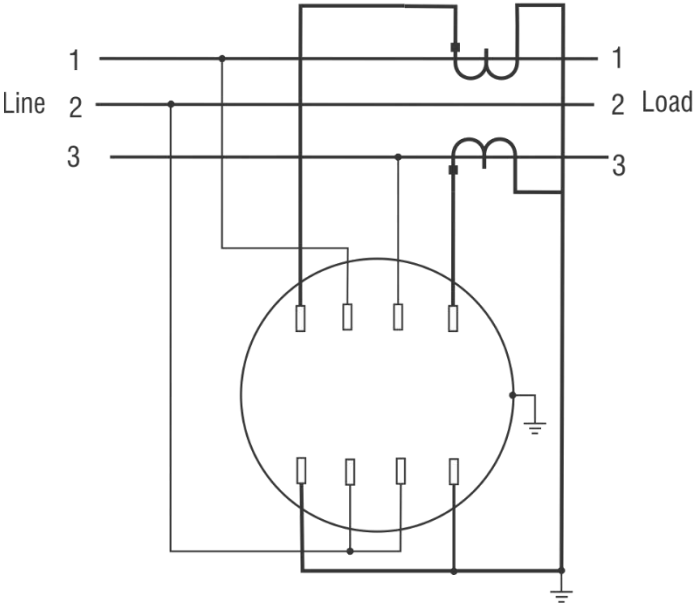

Connections to Socket
(Front View)

Form 5S Delta with two CT and two VTs

Three-Phase Three-Wire Delta With Two CTs and Two VTs

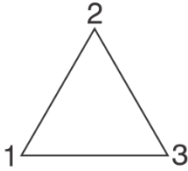

240 volts line-to-line
or 480 volts line-to-line
or 120 volts line-to-line

Form 5S

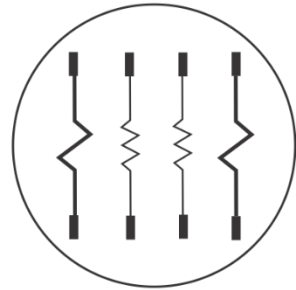

Meter Internal Wiring
(Front View)

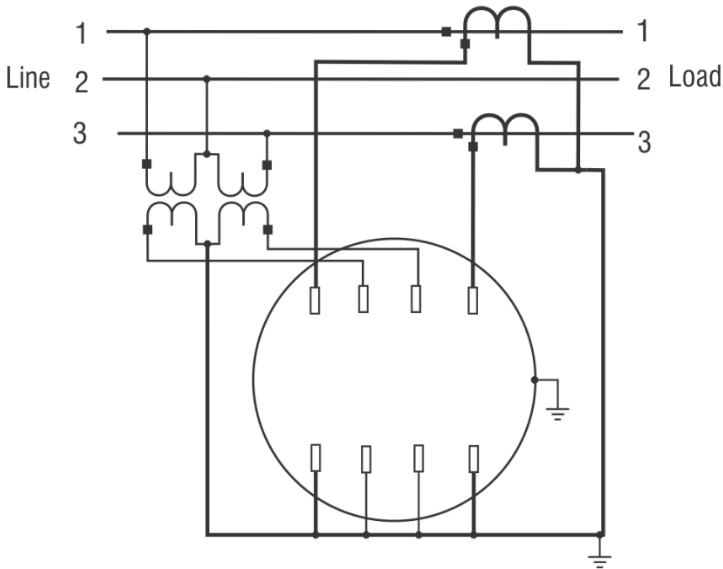

Connections to Socket
(Front View)

Form 5S Delta with two equal-ratio CTs

**Three-Phase
Four-Wire Delta
With Two Equal-Ratio CTs**

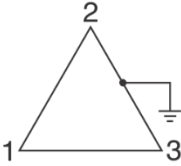

240 volts: 1 to 2, 2 to 3, 3 to 1
120 volts: 2 to neutral, 3 to neutral
208 Volts: 1 to neutral

Form 5S

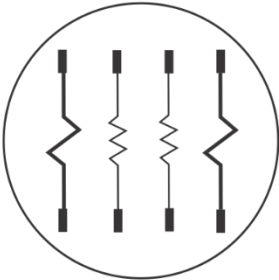

Meter Internal Wiring
(Front View)

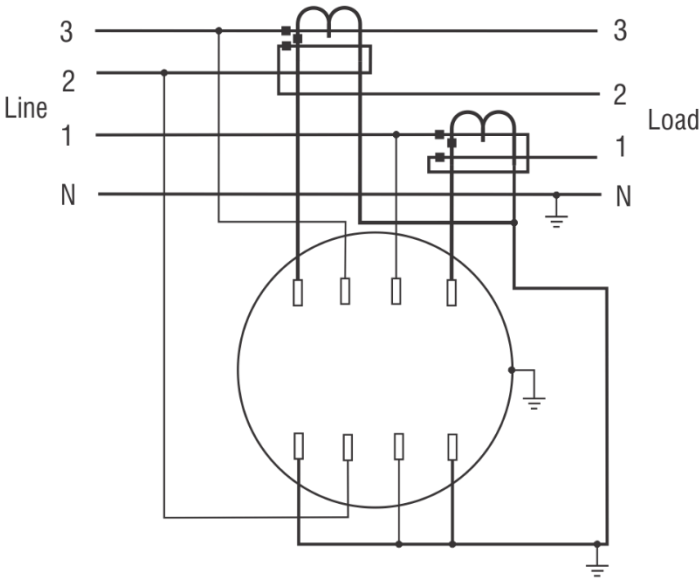

Connections to Socket
(Front View)

Form 5S Wye with three CTs

Three-Phase Four-Wire Wye With Three CTs

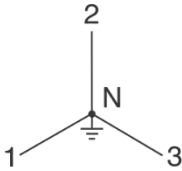

208 volts line-to-line
120 volts line-to-neutral
or
480 volts line-to-line
277 volts line-to-neutral

Form 5S

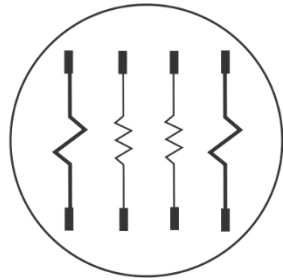

Meter Internal Wiring
(Front View)

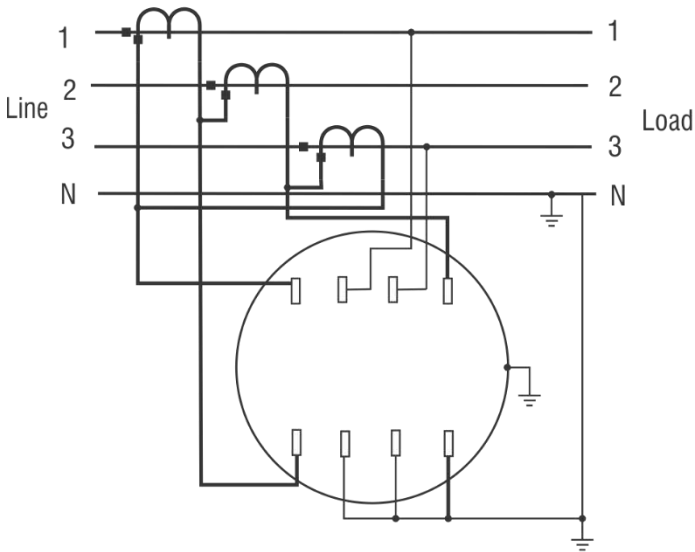

Connections to Socket
(Front View)

Form 5S Wye with equal-ratio CTs

**Three-Phase
Four-Wire Wye
With Two Equal-Ratio CTs**

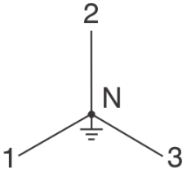

208 volts line-to-line
120 volts line-to-neutral
or
480 volts line-to-line
277 volts line-to-neutral

Form 5S

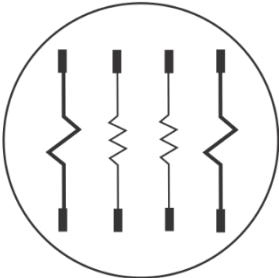

Meter Internal Wiring
(Front View)

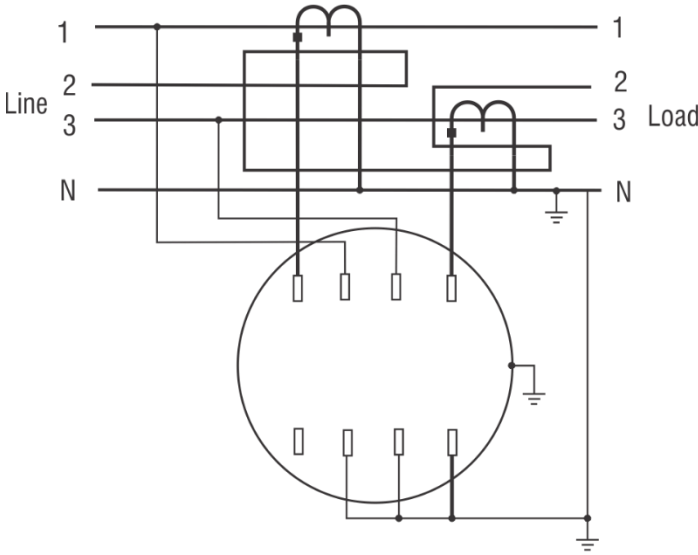

Connections to Socket
(Front View)

Form 5S Wye with three CTs and two VTs

Three-Phase Four-Wire Wye With Three CTs and Two VTs

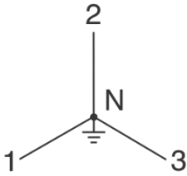

208 volts line-to-line
120 volts line-to-neutral
or
480 volts line-to-line
277 volts line-to-neutral

Form 5S

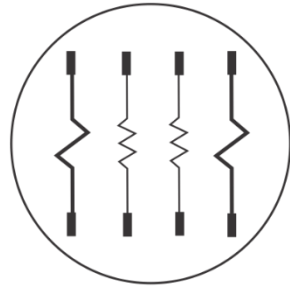

Meter Internal Wiring
(Front View)

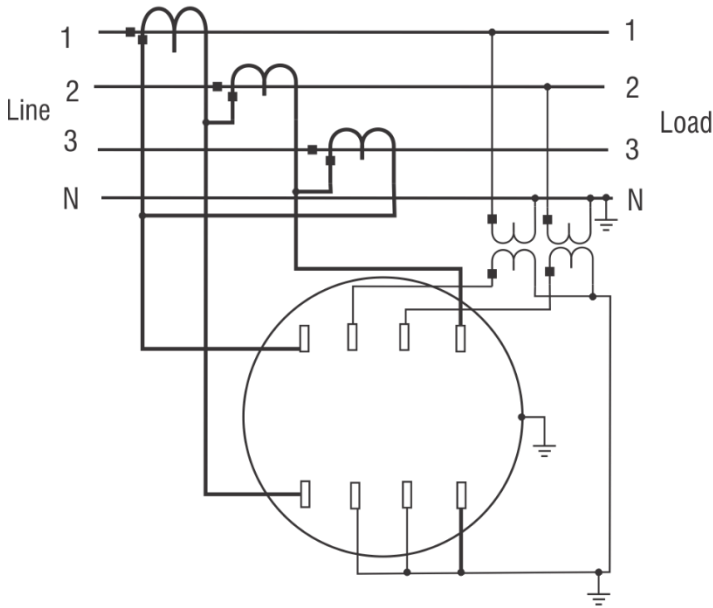

Connections to Socket
(Front View)

Form 12S(N) Network

Three-Wire Network

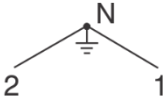

120 volts line-to-neutral
208 volts line-to-line

Form 12S

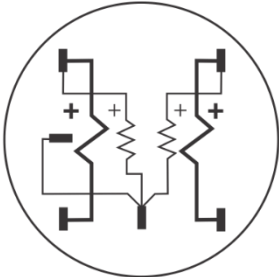

Meter Internal Wiring
(Front View)

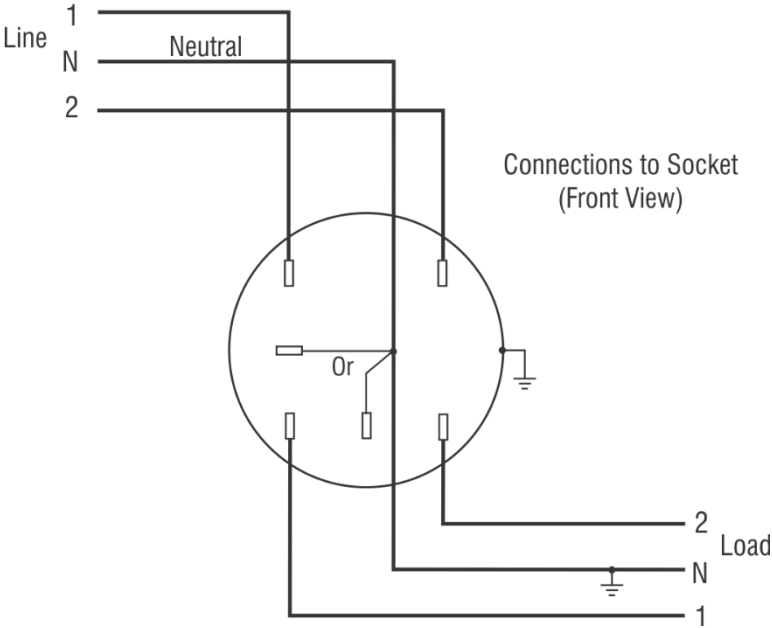

Form 12S Delta

Three-Phase Three-Wire Delta

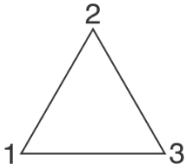

240 volts line-to-line
or 480 volts line-to-line
or 120 volts line-to-line

Form 12S

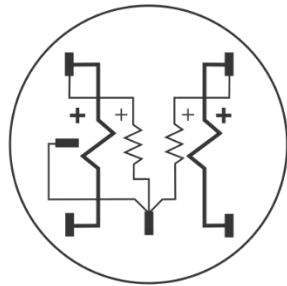

Meter Internal Wiring
(Front View)

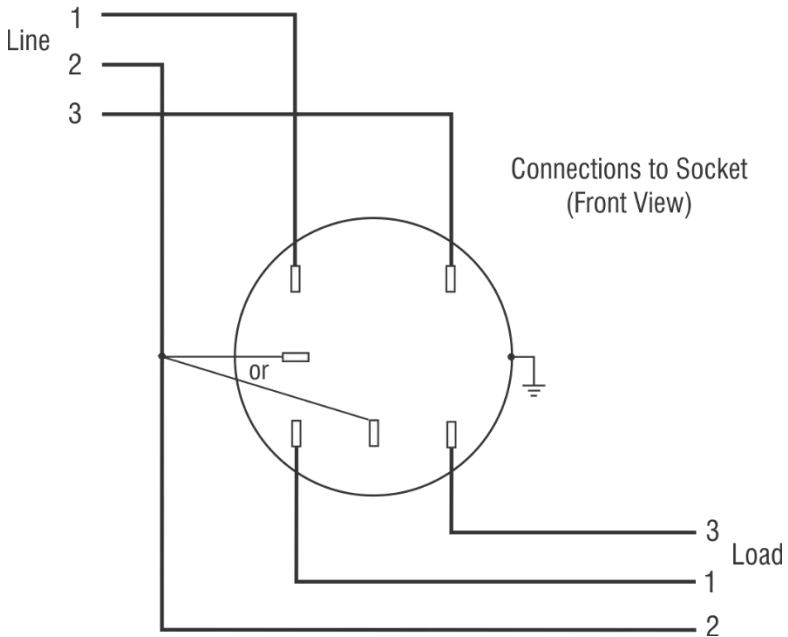

Form 35S Delta

Three-Phase Three-Wire Delta

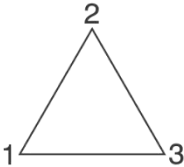

240 volts line-to-line
or 480 volts line-to-line
or 120 volts line-to-line

Form 35S

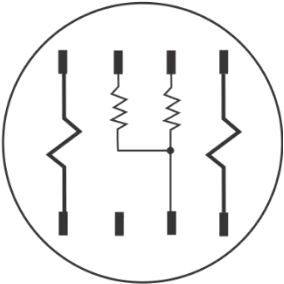

Meter Internal Wiring
(Front View)

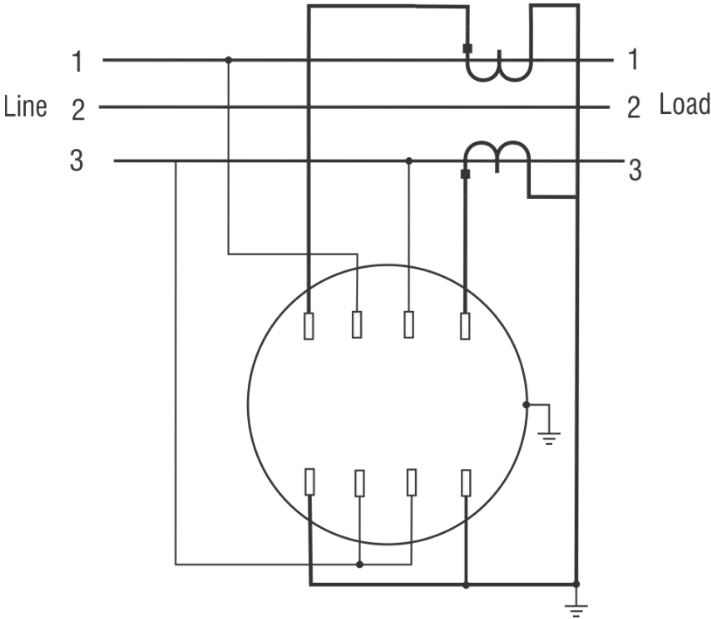

Connections to Socket
(Front View)

Form 45S Delta with two equal-ratio CTs

Three-Phase Four-Wire Delta With Two Equal-Ratio CTs

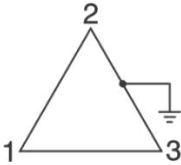

240 volts: 1 to 2, 2 to 3, 3 to 1
120 volts: 2 to neutral, 3 to neutral
208 Volts: 1 to neutral

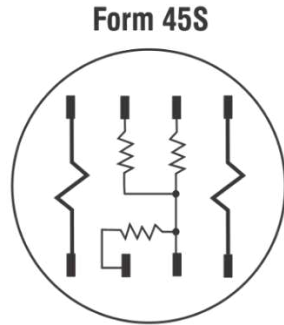

Meter Internal Wiring
(Front View)

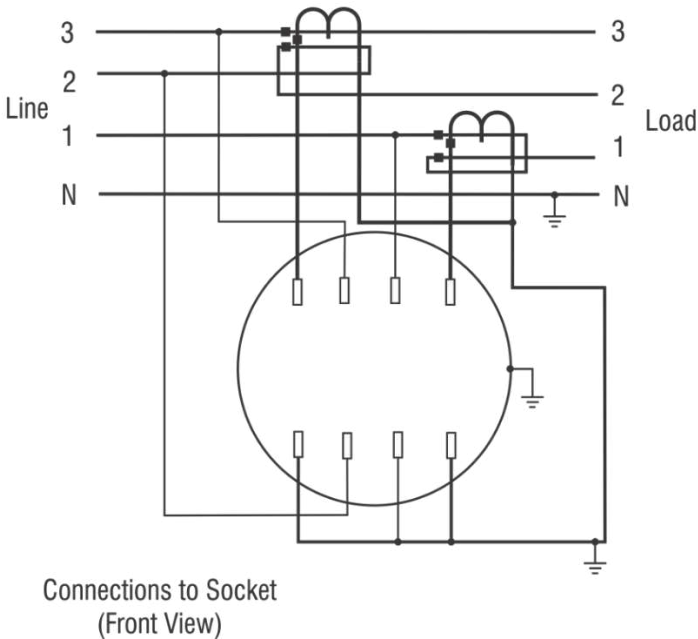

Note: To fully test a meter form 45S, you **must** also test it as a 5S.

Form 45S Wye with equal-ratio CT and two VTs

**Three-Phase
Four-Wire Wye
With Equal-Ratio Cts
and Two VTs**

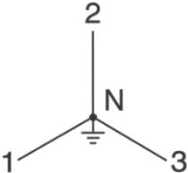

208 volts line-to-line
120 volts line-to-neutral
or
480 volts line-to-line
277 volts line-to-neutral

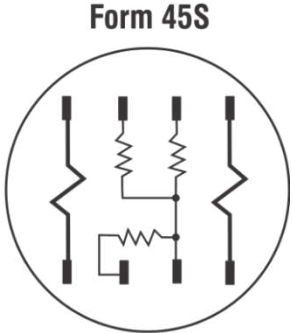

Meter Internal Wiring
(Front View)

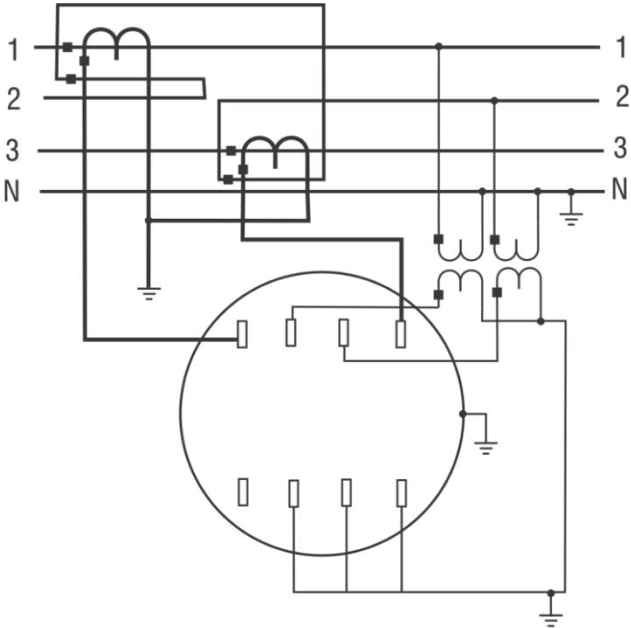

Connections to Socket
(Front View)

Note: To fully test a meter form 45S, you **must** also test it as a 5S.

Appendix C

Form Configurations

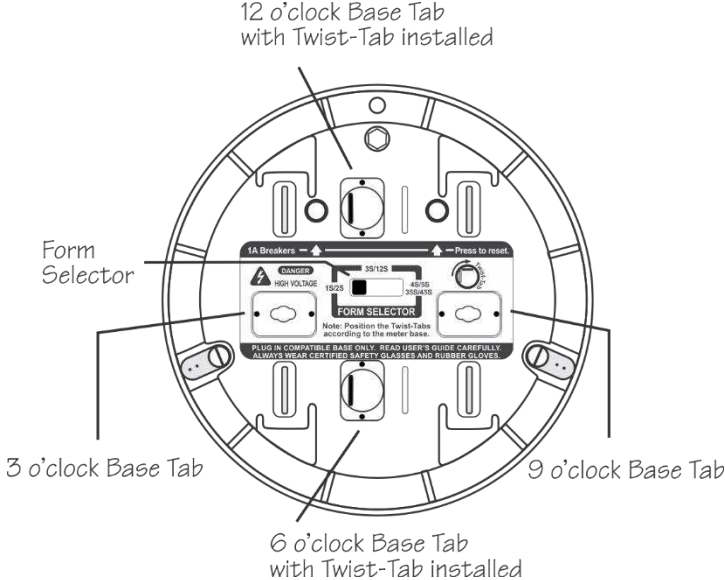

Forms	3 o'clock	12 o'clock	6 o'clock	9 o'clock	Form Selector
1S, 2S					
3S, 12S					
4S					
5S 35S, 45S					

Appendix D

Troubleshooting

If the MT-1/NT5 seems to have operation problems, consult the following list to help determine the source of the problem. If any problem persists, please contact Probewell Lab Inc. Technical Services.

FAULT	DESCRIPTION	FIX
AT POWER ON THE SOCKET DOES NOT START	The socket is not powering up and no display on the handheld controller	<ul style="list-style-type: none"> • Check if the fan inside the socket is running. • Make sure the form selector is set according to the meter base being used. • Verify the voltage of the meter base between 100 and 480VAC. • The meter base must be able to provide at least 150VA • Do not install tester in a test board.
AT POWER ON THE REMOTE CONTROL DOES NOT WORK	If the fan inside the socket is running but the remote control's display is blank	<ul style="list-style-type: none"> • Check the coiled cables for damaged connector • Check the contacts of the coiled cable at both ends • Check the RJ12 connector on the handheld and the socket. • Try another coiled cable

FAULT	DESCRIPTION	FIX
<p>METER UNDER TEST DOES NOT WORK</p>	<p>If the meter is not powering up after selection of the form</p>	<ul style="list-style-type: none"> • Make sure the selected Form matches with the one indicated on the meter nameplate. • Turn the MT-1/NT5 off and on and try again. • Check meter insertion. • The meter could be defective. Try another meter.
<p>NO PULSE FOUND (SOLID-STATE METERS)</p>	<p>If the remote control displays "Waiting....." and nothing happen.</p>	<ul style="list-style-type: none"> • Make sure the sensor is positioned over the IR pulse emitter of the meter. • Some meters need to be set in Test Mode to emit a proper pulse for testing. See the meter user manual
<p>METER NOT INSTALLED</p>	<p>The socket is not detecting the meter current elements and a message meter not installed is displayed on the handheld controller.</p>	<ul style="list-style-type: none"> • Make sure the meter tabs are fully plugged in MT-1/NT5 front jaws. • Check if the front jaws of the MT-1/NT5 socket are clean and in good condition. • Check the meter's contacts for good condition and cleanliness. • Try another meter. • Turn off and on the MT-1/NT5 and start again.

FAULT	DESCRIPTION	FIX
<p>METERCAM IS NOT SYNCHRONIZED WITH THE DISK</p>	<p>The Metercam is not detecting correctly the black flag on the disk</p>	<ul style="list-style-type: none"> • Make sure the Kh of the remote control does correspond to the one indicated on the nameplate of the meter. • Reposition Metercam and start test over again.
<p>METERCAM KEEPS ON SCANNING WITHOUT FINDING THE DISK</p>	<p>The Metercam is not detecting the black flag on the disk of the meter being tested.</p>	<ul style="list-style-type: none"> • Check if the disk is turning. • Check the dick of the meter is in the Metercam disk zone. • Check that the suction cups are adhering properly on the meter face. If needed, lightly wet the suction cups.

FAULT	DESCRIPTION	FIX
<p>HIGH ERROR OR OVER% RESULT</p>	<p>After completion of test you have results with high value or OVER%.</p>	<ul style="list-style-type: none"> • Make sure the Kh of the remote control does correspond to the one indicated on the nameplate of the meter. • Without pickup, this indicates a bad synchronization at the beginning and the end of a test. Start the test again with a higher number of revolutions. The meter might be defective. • If the Metercam is used, make sure that the 4 suction cups stick perfectly on the meter cover during the entire test. • Some meter requires to be put in TEST MODE to stop the pulses from the communication module. Check meter user manual for details. • With a communication module, restart the test but remove the head of the Optical Pickup from the meter and select your meter form on the remote, then wait about 15 to 20 seconds before putting the head back on meter. This will let the test pulse from the AMI module pass and you will get a proper Kh evaluation.

Error Messages

When an error message is displayed on the remote control, it means that the MT-1/NT5 has detected something wrong in the system. If any of the messages still appear after a second powering on, please contact Probewell Lab Inc. Technical Service.

ERROR MESSAGE	DESCRIPTION	FIX
COM ERROR: 91!	A communication error between the socket and the remote control has been detected. When this message is displayed, the meter does not power up.	<ul style="list-style-type: none"> • Check cable connection • Check if your cable(s) are connected in the right order with the unit and the pickup you are using, check description of pickups in the user guide for proper connections. • If this message still appears, please contact Probewell Lab Inc. Technical Service.
CONFIG ERROR!	An error in the EEPROM memory of the handheld remote control has been detected. The configuration of the user is stored in this memory.	<ul style="list-style-type: none"> • It is possible at this time to come back to the manufacturer's configuration by pressing PF. • If the message still appears after a second powering on, please contact Probewell Lab Inc. Technical Service.
CAL.DATA ERROR!	An error in the EEPROM memory of the socket has been detected. The calibration values are stored in this memory.	<ul style="list-style-type: none"> • If the message continues to appear, please contact Probewell Lab Inc. Technical Service.

ERROR MESSAGE	DESCRIPTION	FIX
CHECKSUM ERROR!	An error in the EEPROM memory of the socket has been detected.	<ul style="list-style-type: none"> • If the message continues to appear, please contact Probewell Lab Inc. Technical Service.
DATALOG MEMORY ACCESS ERROR!	An error in the EEPROM memory of the socket has been detected. The Datalog results are stored in this memory.	<ul style="list-style-type: none"> • If the message continues to appear, please contact Probewell Lab Inc. Technical Service.
MT-1 BIOS ERROR!	An error in the EEPROM memory of the socket has been detected.	<ul style="list-style-type: none"> • If the message continues to appear, please contact Probewell Lab Inc. Technical Service.
LINE VOLTAGE OUT OF RANGE!	This message appears when the voltage is outside the voltage parameters of the test unit (100-480 VAC).	<ul style="list-style-type: none"> • Check input voltage. • If the message continues to appear, please contact Probewell Lab Inc. Technical Service.
VOLTAGE ON FRONTSHELL!	This message appears while doing a calibration and voltage is detected on the front jaws of the Probewell tester.	<ul style="list-style-type: none"> • Check connection from the accuracy test jack. • Check that there is no connection between the auxiliary power and potential input of your standard. • If the message continues to appear, please contact Probewell Lab Inc. Technical Service.

ERROR MESSAGE	DESCRIPTION	FIX
ERROR CAN'T TEST SENSUS METER!	This message appears after you answered "YES" at testing SENSUS meters and "NO" at using a 3S ADAPTER.	<ul style="list-style-type: none"> • Use an adapter to test the 3S SENSUS meters. • The 4S SENSUS meter cannot be tested with the MT-1/NT4. • If the message continues to appear, please contact Probewell Lab Inc. Technical Service.
WRONG FIRMWARE!	The handheld is not detecting the right socket to work with.	<ul style="list-style-type: none"> • You are using a handheld controller that is not matched to your socket. • If the message continues to appear, please contact Probewell Lab Inc. Technical Service.
SOCKET ERROR!	An error in the EEPROM memory of the socket has been detected. The calibration values are stored in this memory.	<ul style="list-style-type: none"> • If the message continues to appear, please contact Probewell Lab Inc. Technical Service.
CHECK INSERTION!	This message appears when the meter is not making proper contact with the pistons of the meter (only with MT-1/NT5 and MT-1/NT9)	<ul style="list-style-type: none"> • Remove and reinstall meter making sure that it's fully inserted. • With meters without KYZ tab this message will appear just continue the test this will not affect your test. (MT-1/NT9 only)

Appendix E

Parameters for Data Logging Option

The following describes all of the different data fields contained in the .CSV (Comma Separated Value) file generated by Probewell's NTDataOne.

- | | |
|---------------|--|
| 1- TEST# | This test # is given to each subsequent test conducted in the field. The unit can store up to 100 tests. Once the tests have been uploaded into your PC and deleted from the remote, the test # restarts at 1. |
| 2- REC# | This is a permanent record number, with the prefix R, and cannot be modified or deleted (already stored in remote). This number is incremented at each new logged test. It starts at R00001 and increment by 1 up to R99999 then restarts at R00001. |
| 3- DATE/TIME | Stamp date and time of the test. |
| 4- REMOTE# | MT-1/NT5 Remote Serial Number (already stored in remote). |
| 5- SOCKET# | MT-1/NT5 Socket Serial Number (already stored in socket). |
| 6- FORM | Meter forms can be 1S, 2S, 3S, 4S, 5S(35S), 12S and 45S. |
| 7- PHASE | Phases of meter under test with MT-1/NT5 only. |
| 8- TA | Testing Amperage of meter tested. |
| 9- Kh | Kh of the meter tested. |
| 10- MODE | Mode in which test was conducted. Result can be: PRESET or USER. |
| 11- SENSOR | Indicates what type of sensor was used during test. Result can be PULSE or CAM. |
| 12- METER ID: | Tested meter's serial number as entered by the technician in the field. |
| 13- %HL | Result of HL test in registration percentage. |
| 14- %LL | Result of LL test in registration percentage. |
| 15- %WT | Weighted average in registration percentage as calculated with the configured ratio. |

16- %PF	Result of PF test in registration percentage.
17- CREEP	Status and result of creep test. There are 4 possible answers:
a) N/A	This will be returned when the %HL and %LL error difference falls within the acceptable error margin and no creep test needs to be run.
b) SKIP	This will be returned when the %HL and %LL error difference is outside the acceptable error margin, but the technician decided not to run a creep test.
c) YES	This will be returned when the %HL and %LL error difference is outside the acceptable error margin; a creep test has been run and the technician answers YES to the question: Does the meter creep?
d) NO	This will be returned when the %HL and %LL error difference is outside the acceptable error margin; a creep test has been run and the technician answers NO to the question: Does the meter creep?
18- 25 []	8 programmable questions. Each programmable question will be transferred between brackets []. Answers will be transferred without brackets.
26- RevHL	Revolutions run during HL test.
27- RevLL	Revolutions run during LL test.
28- RevPF	Revolutions run during PF test.
29- RatioWT	Weighted error ratio as defined in configuration.
30- AmpHL	Load in amps applied during HL test.
31- AmpLL	Load in amps applied during LL test.
32- AmpPF	Load in amps applied during PF test.
33- WhHL	Watthours recorded during HL test.
34- WhLL	Watthours recorded during LL test.
35- WhPF	Watthours recorded during PF test.
36- VOLT	Line voltage recorded at end of all tests.
37- FREQ	Line Frequency recorded at end of all tests.

Appendix F

Customer Service

If your MT-1/NT5 becomes defective while under warranty (two years after original date of purchase) Probewell Lab Inc. will repair or replace it. If the unit becomes defective after the warranty has expired, Probewell Lab. Inc. will repair it charging the cost of labor and spare parts.

Please do not return your MT-1/NT5 without contacting customer service at 1-866-626-1126 or send an email at info@probewell.com. Detailed delivery procedure will be provided to you.

If you have a technical question regarding the MT-1/NT5 operation, contact the technical support at 1-866-626-1126 or send an email at support@probewell.com.

Appendix G

Recommendations

Probewell Lab Inc. suggests that you respect the following recommendations in order to gain maximum use of the MT-1/NT5 and its accessories for many years. **Any unauthorized modifications or broken seals will immediately void the guarantee and any further services.**

MT-1/NT5

- Do not try to open the MT-1/NT5 socket; there are no serviceable parts inside.
- Never block the air vents on the MT-1/NT5 socket.
- Never expose equipment to bad weather or direct rain.
- Keep front jaws and rear tabs clean. Use lubricant for electric contacts. **Do not** use any abrasive materials.
- Never use **solvents** to clean the MT-1/NT5. Use a soft moist cloth with non-abrasive soap to clean surface.
- Handle the MT-1/NT5 with care.

Metercam & Optical Pickup

- Do not try to open; there are no serviceable parts inside.
- Never expose equipment to bad weather or direct rain. Do not expose to direct sunlight for long periods at a time.
- Keep the back window of the Metercam and the suction cups clean. **Do not** use any abrasive materials. Use a soft moist cloth with non-abrasive soap to clean surface. Use mineral oil to soften hardened suction cups.
- Handle both pickups with care. Use one of the side pouches located inside the carrying bag to store the Metercam and the optical pickup.

Notes

Notes
